

Technical Manual - 3
Technisches Handbuch - 19
Manual técnico - 36
Manuel technique - 53
Teknisk håndbok - 70
יננט קירדמ - 87

Arc Booster

This section details safety critical information related to the use of the Booster and Arc Oven.



Cautions & Warnings

Cautions & Warnings

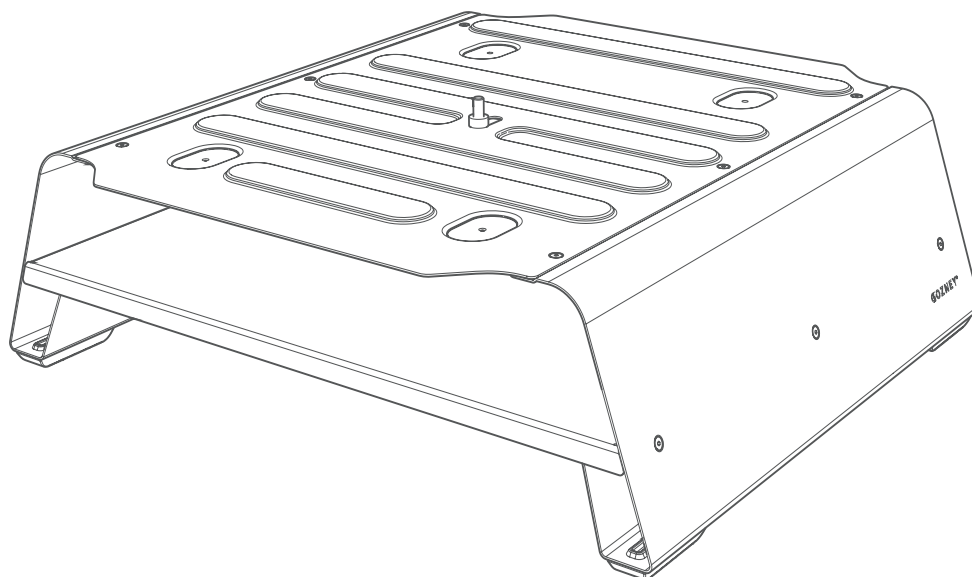

Ensure you have fully read, understood and comply with the cautions & warnings in the Arc Users Manual supplied with the oven.

—

Never attempt to move the oven when it is still warm, wait for it to fully cool first.

—

When moving the oven on the Booster always lift using the oven lifting points, not the Booster or shelf.

—

Remove anything loose from the Booster and its shelves before moving it.

Placing hot items from the oven onto the shelf may damage the coating, use appropriate protection to avoid damage.

Gas Oven

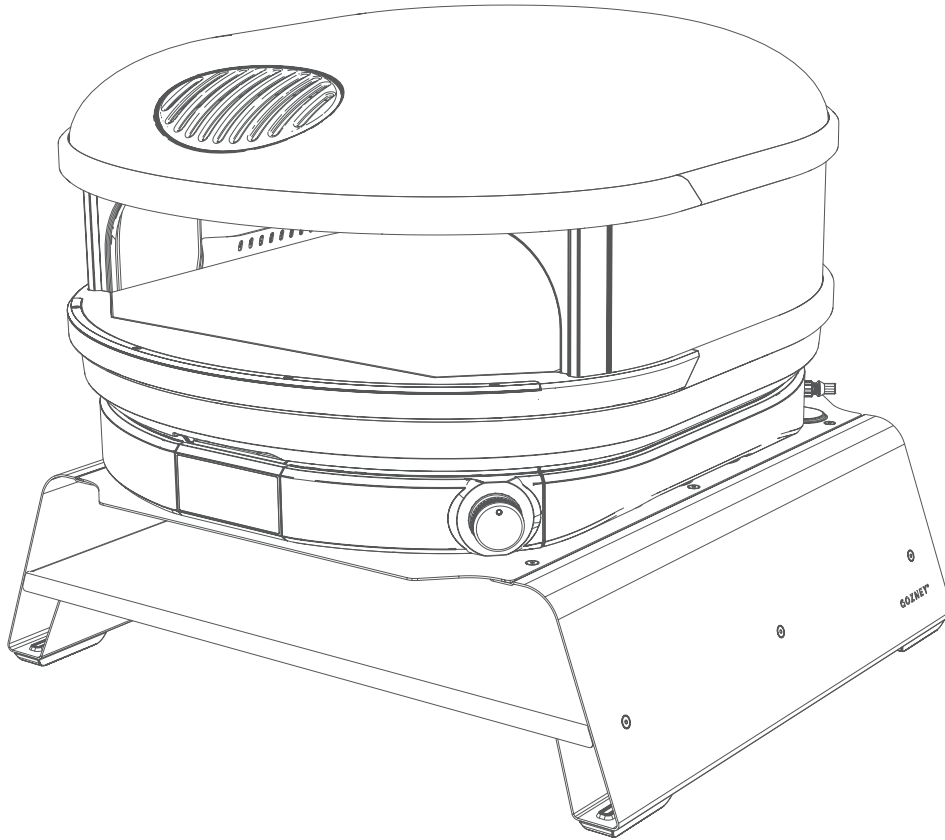

Always disconnect the oven from the gas supply before moving the oven.

—

Ensure you're using a Gozney supplied gas connector or one that complies with the Standard for movable gas appliances (ANSI Z21.69 / CSA 6.16), and a quick-disconnect device that complies with the relevant Standards (ANSI Z21.41 / CSA 6.9).

The gas connector and the quick disconnect device or its associated piping should never be used to limit the movement of the appliance.

This section details the process of building the Booster and its installation.



Building & Installation

Build Manual

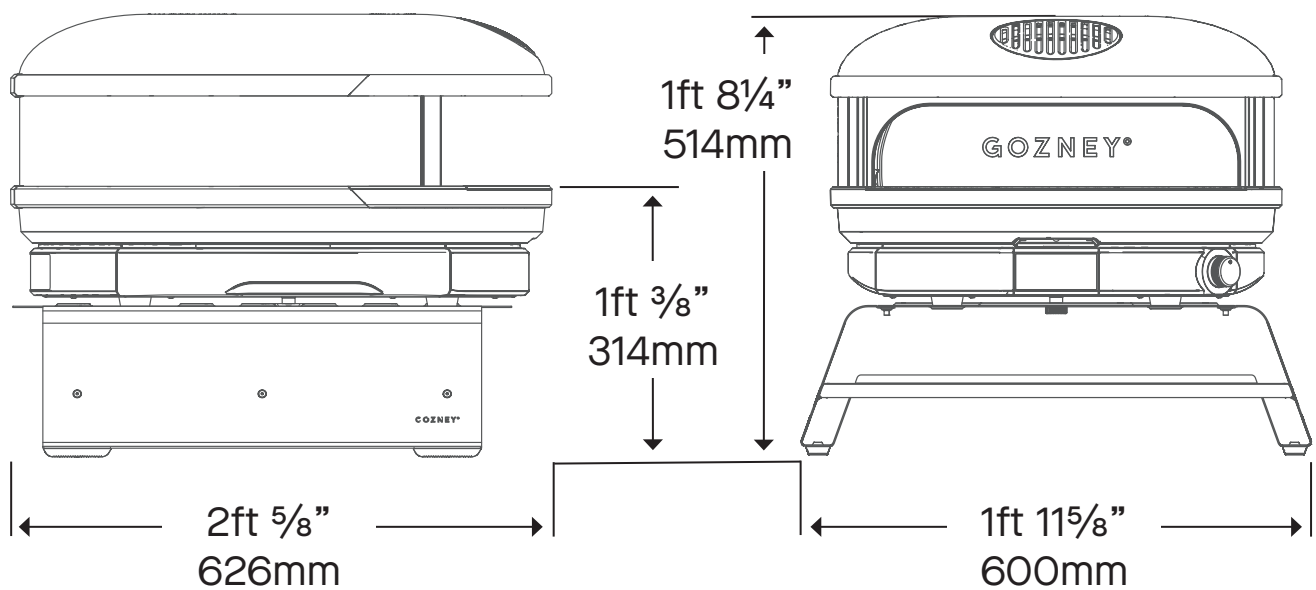

BUILD AREA

Build the Booster in the area you intend to position Arc.

—
Ensure the surface is stable, level and capable of supporting the oven's weight.

—
Don't place any of the parts on an abrasive surface and avoid damaging the paintwork of the metal parts.

What's In The Box

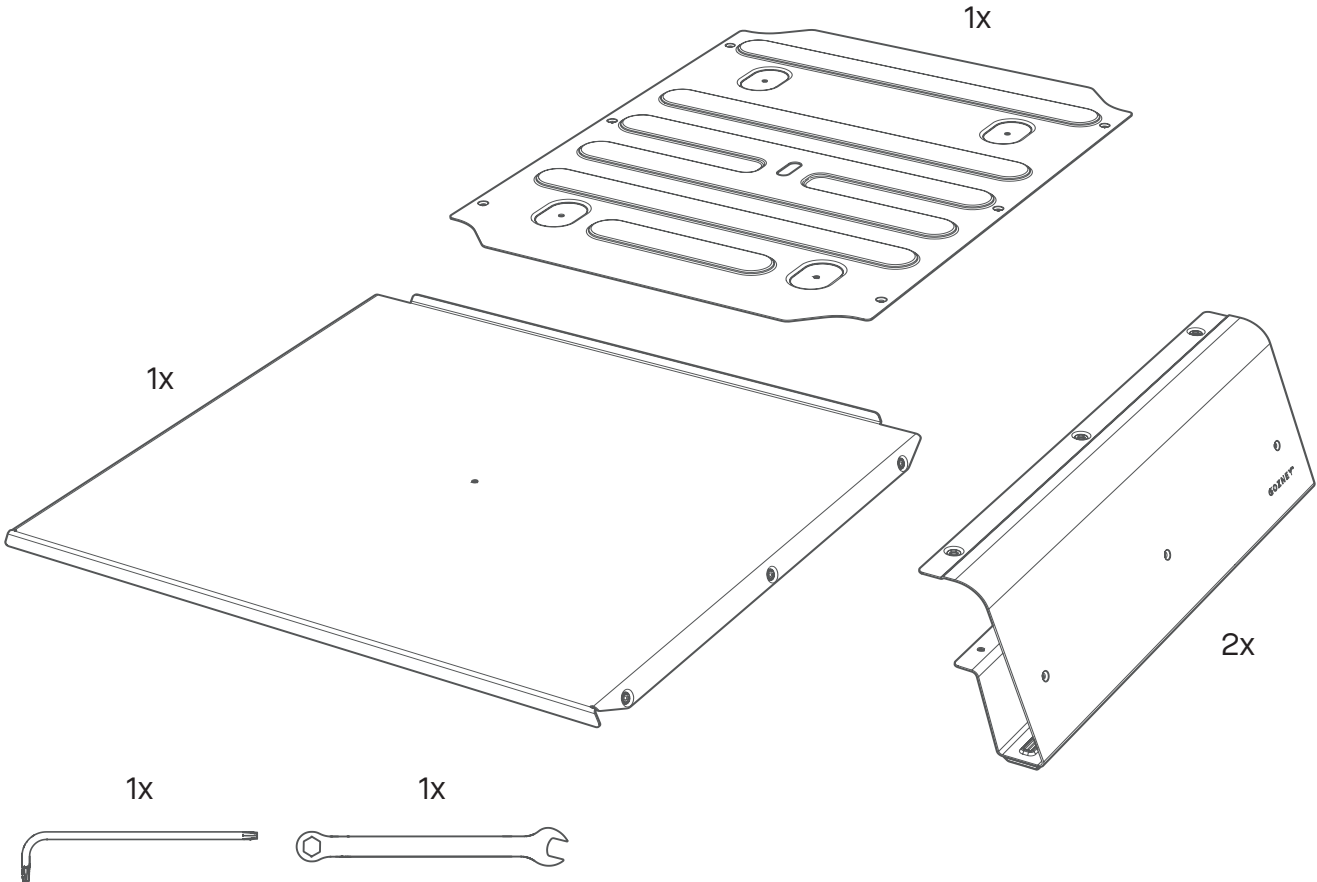

SCALE 1:1

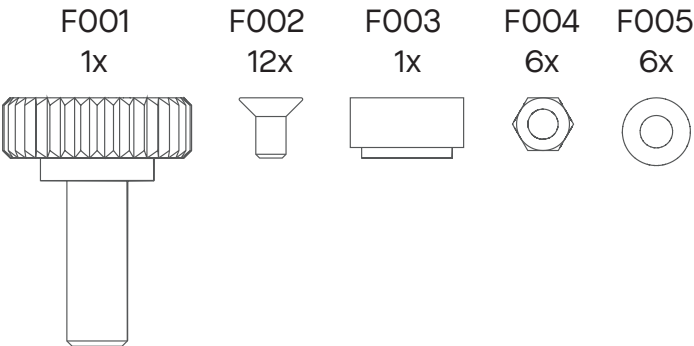

Step 1



FIXINGS WARNING

We recommend not fully tightening all nuts and bolts until the Booster has been assembled.

—
This will ease the alignment of future fixings.
Fully tighten at Step 6.

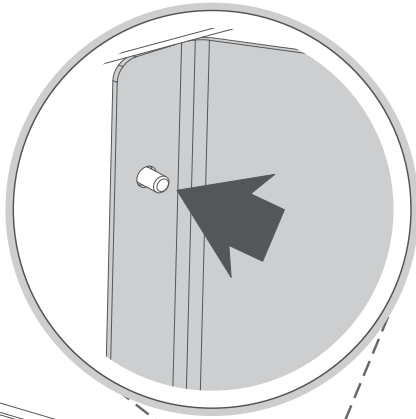

F002
3x

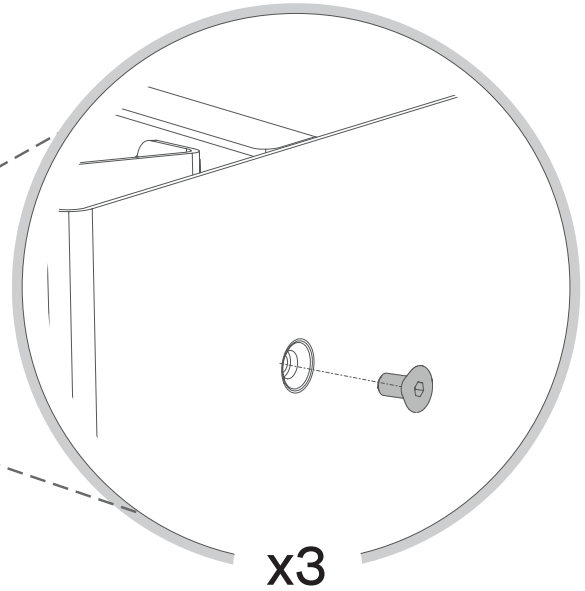
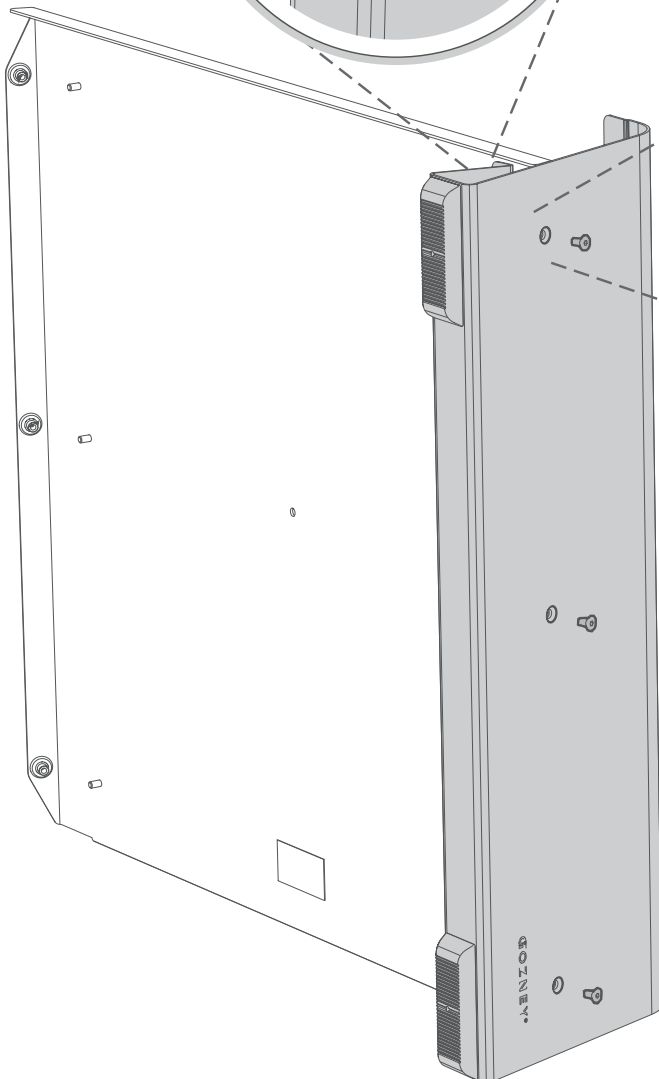

Step 2



F005
3x

F004
3x

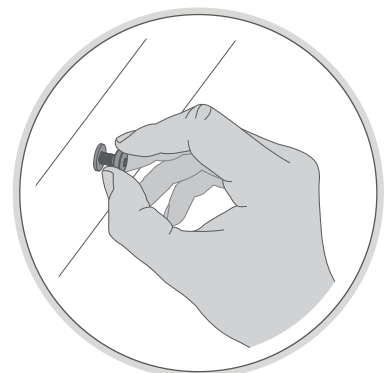
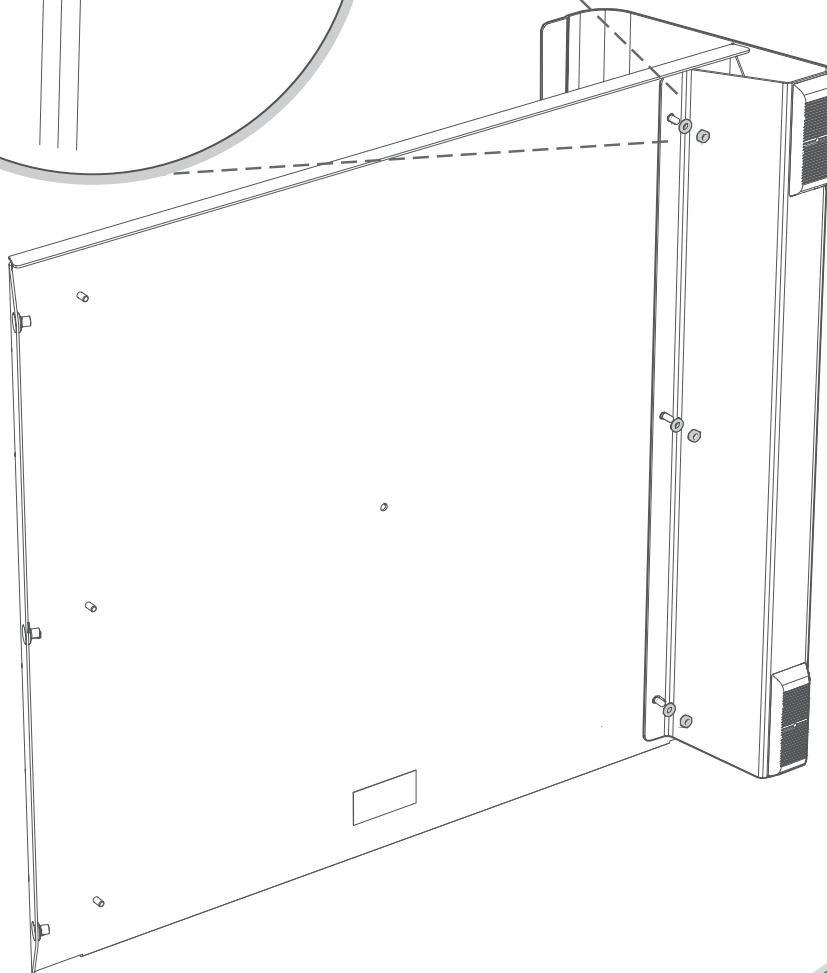
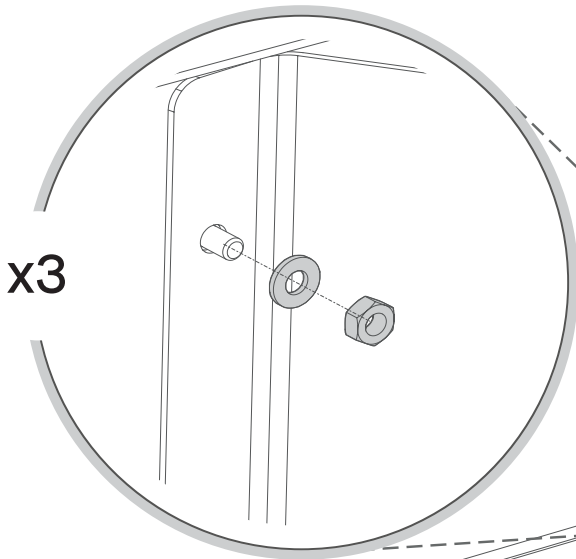

Step 3



F002
3x

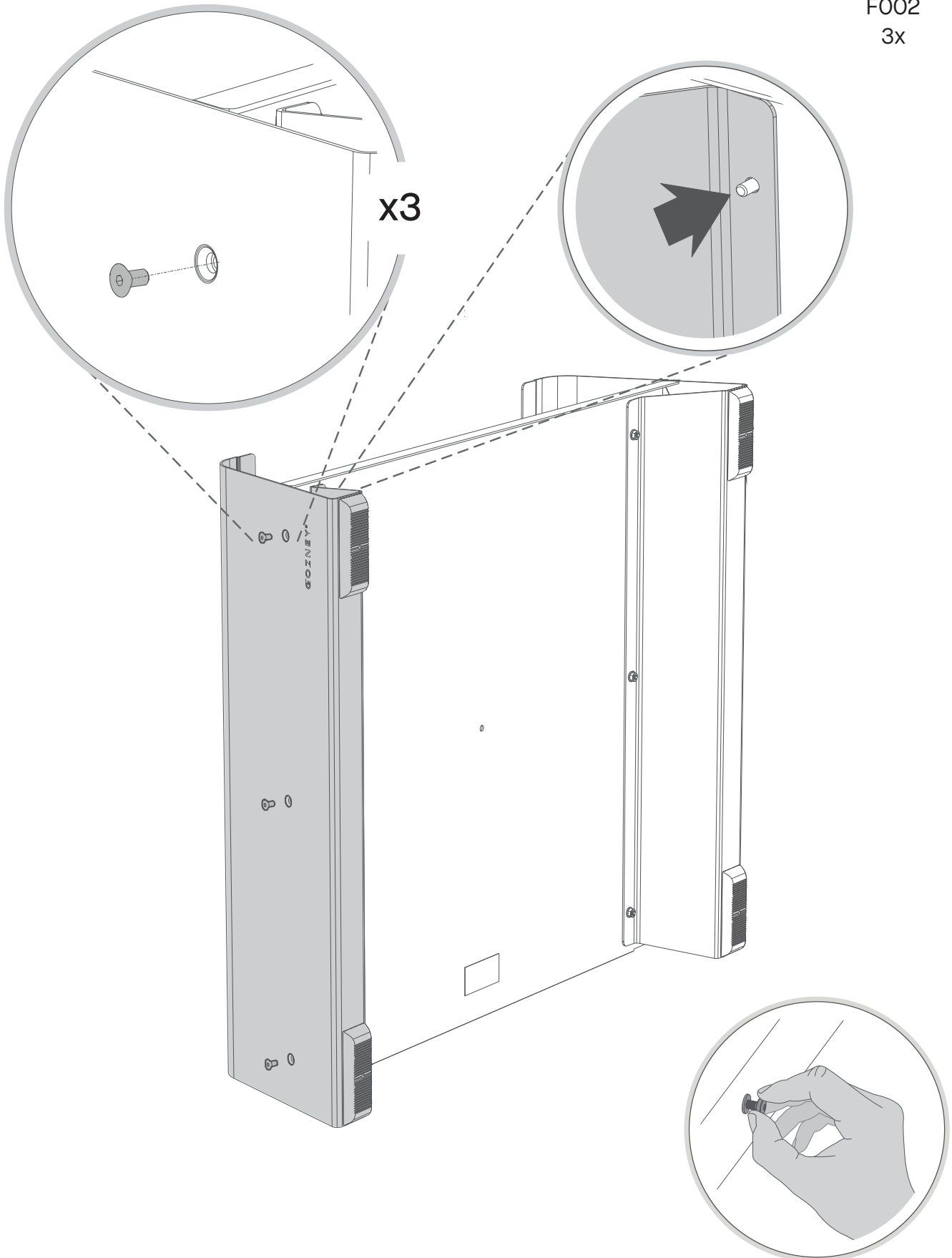

Step 4



F005
3x

F004
3x

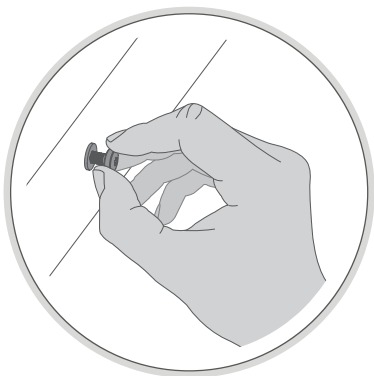
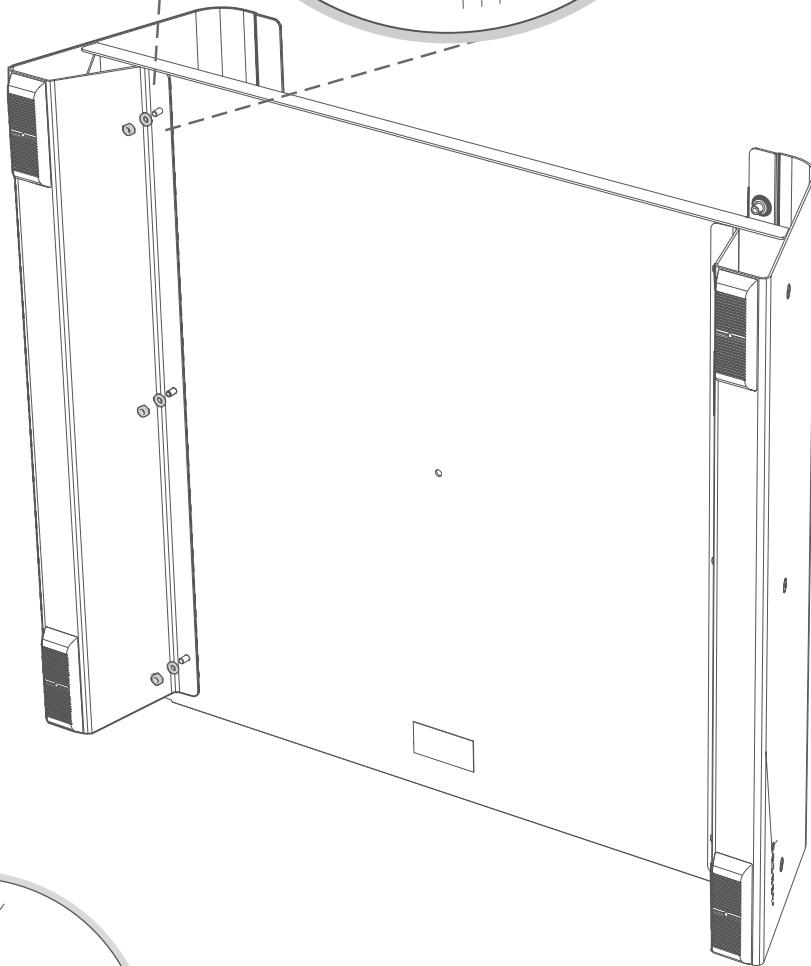
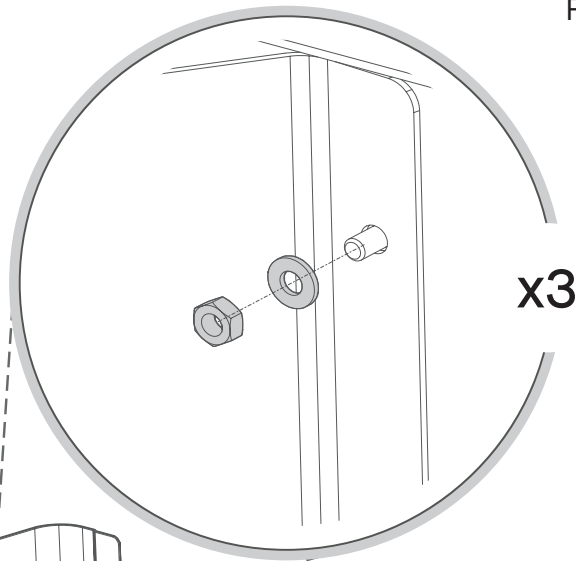

Step 5



F002
6x

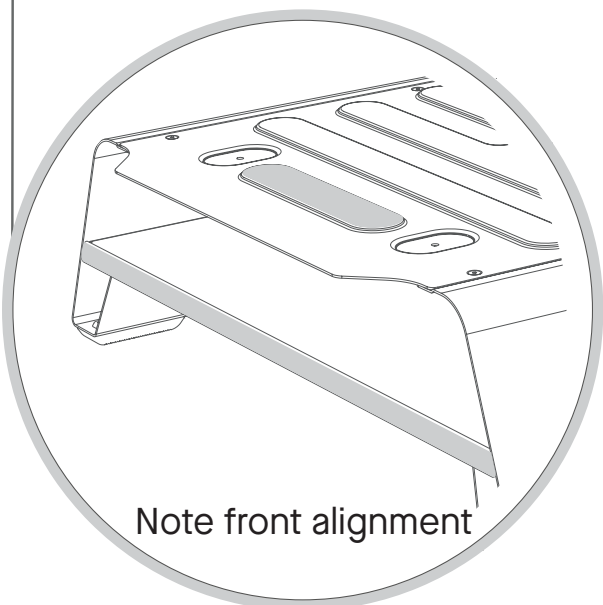
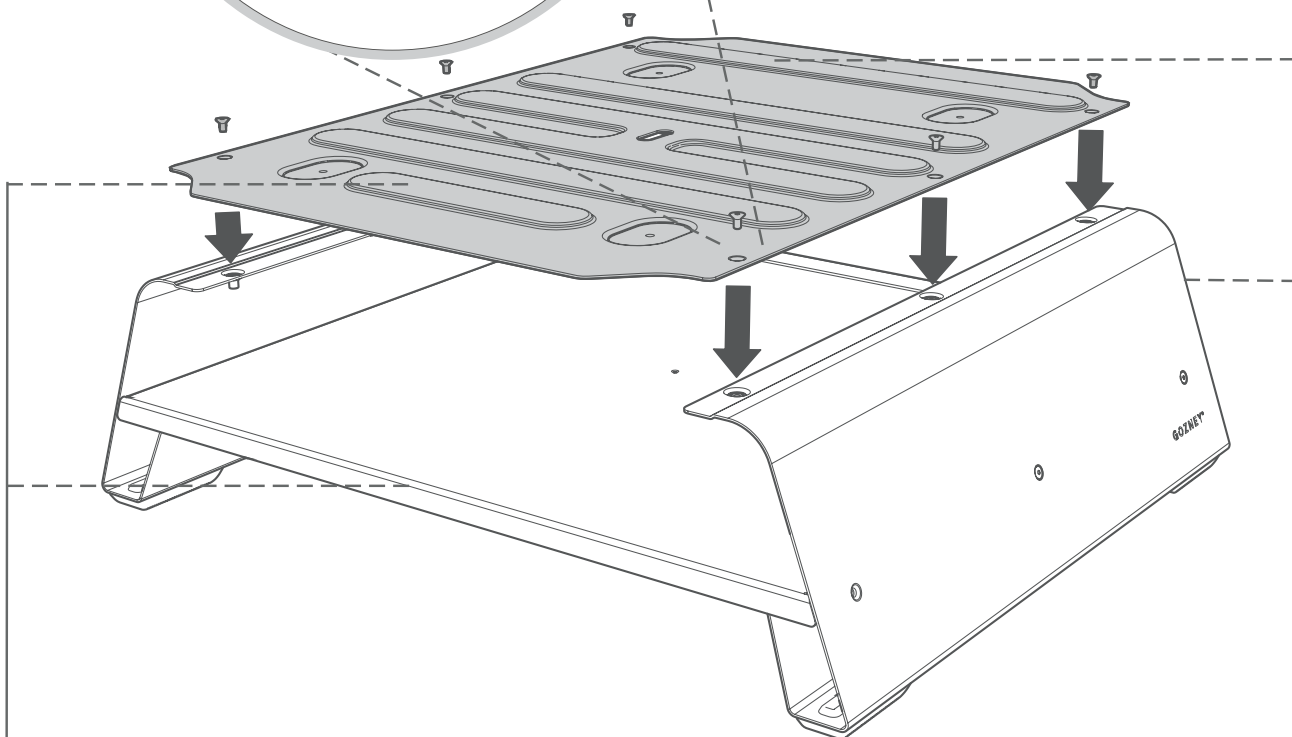
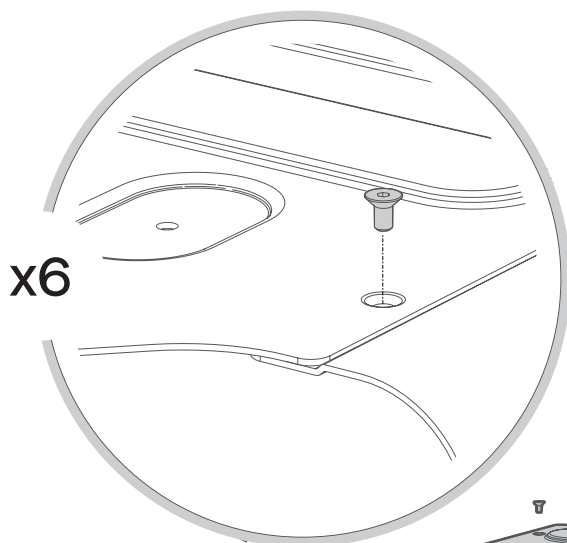

Note front alignment

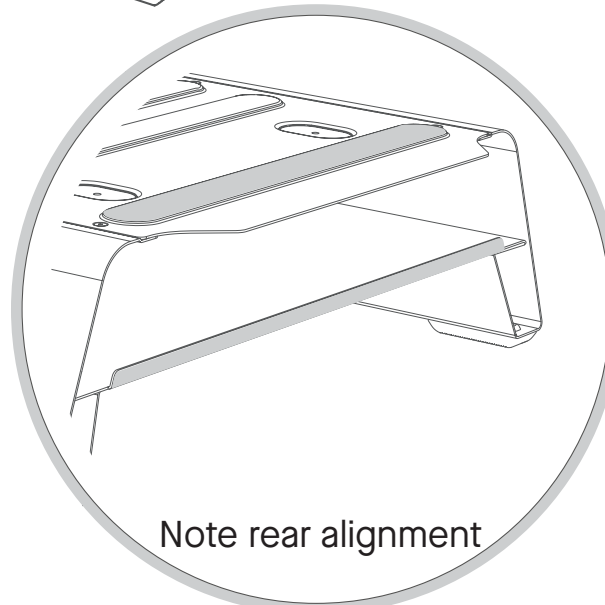

Note rear alignment

Step 6

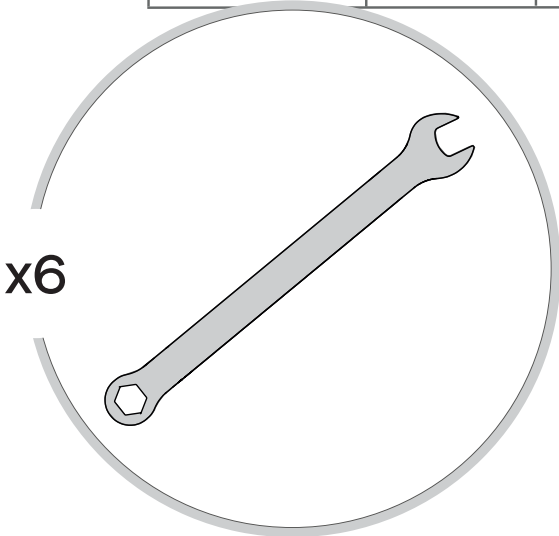
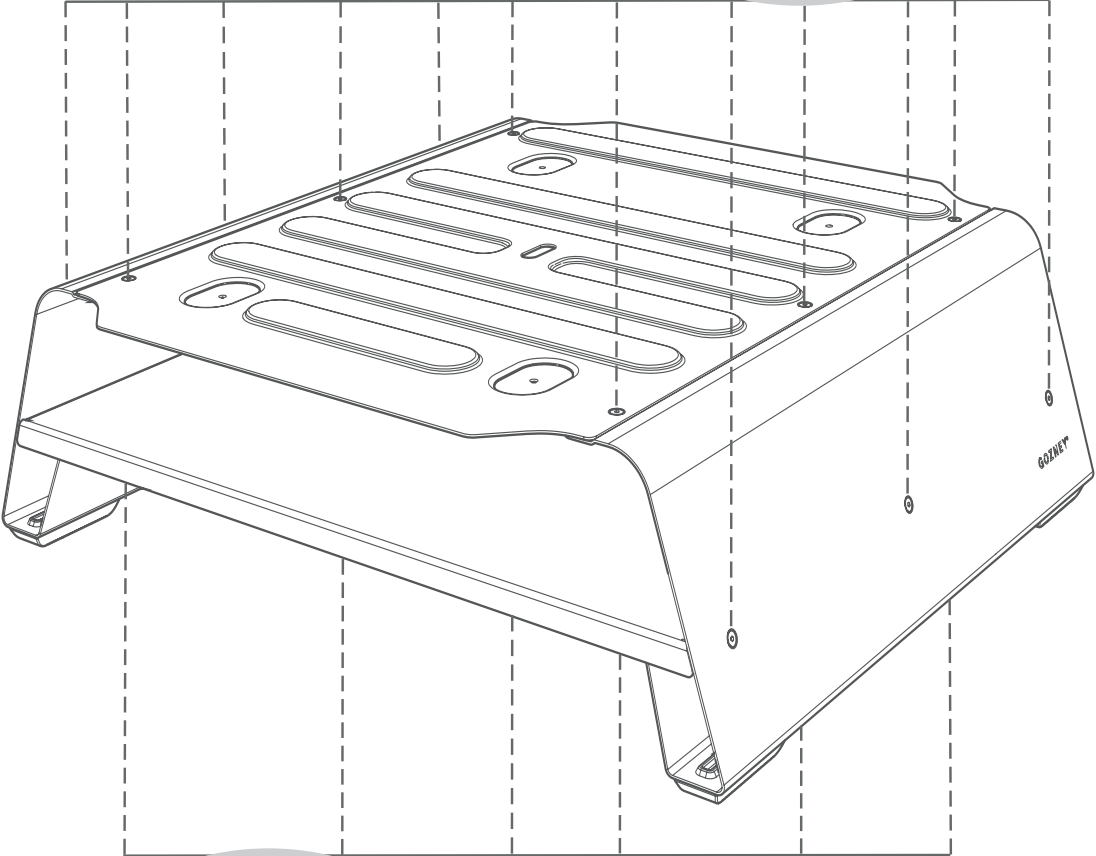
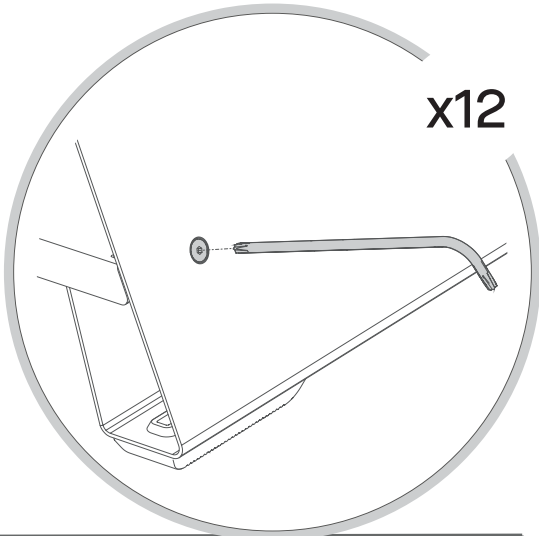

FIXINGS

Tighten all fixings on the Booster, being careful not to over tighten.

Step 7

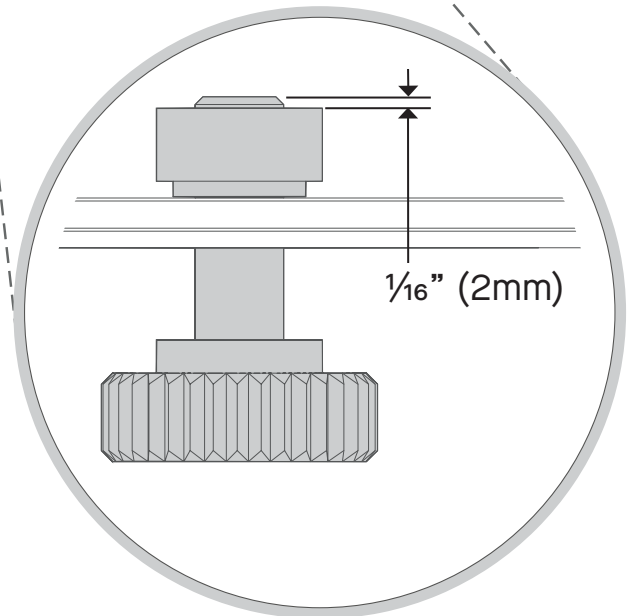
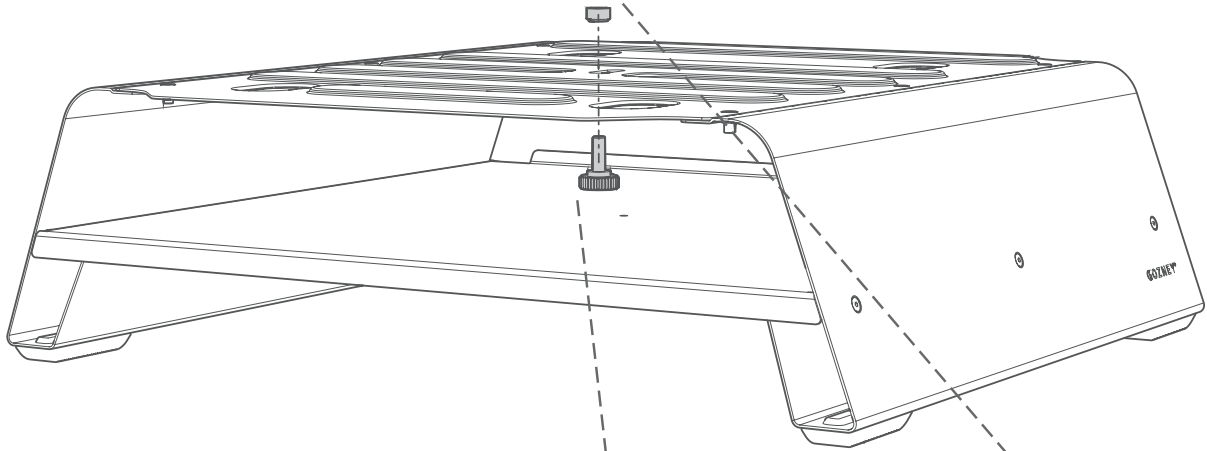
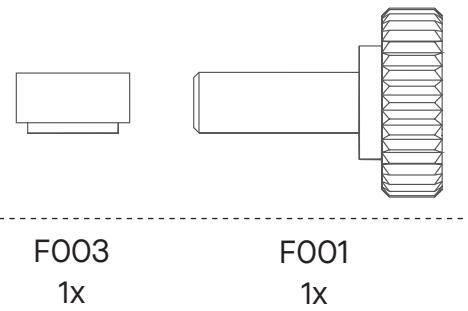

INSTALLING ARC

Before installing Arc, assemble fixings F001 and F003 into the top of the Booster.

Do not fully tighten these two fixings, there should be no more than $\frac{1}{16}$ " (2mm) of thread exposed

Step 8

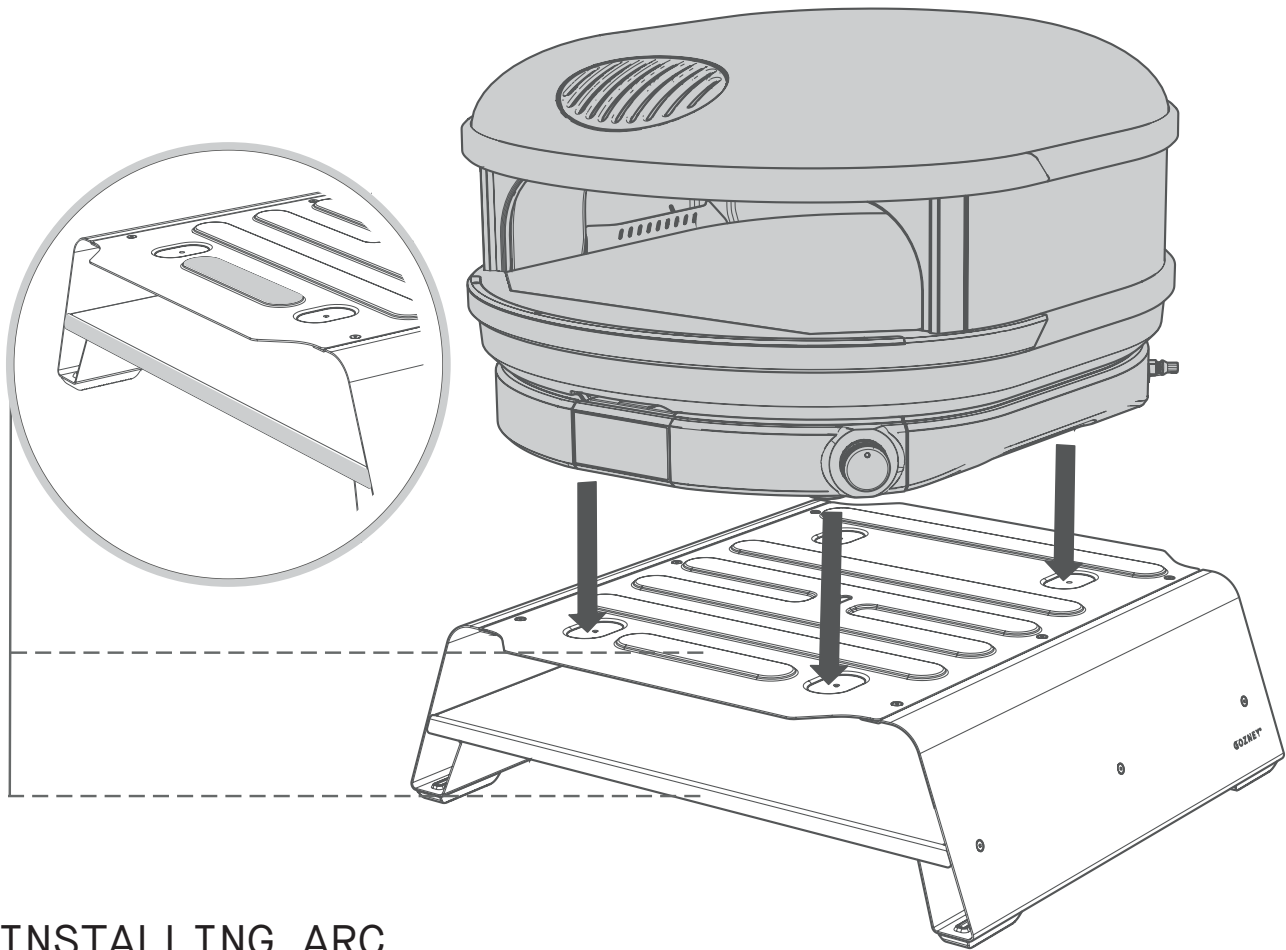

INSTALLING ARC

Ensure fixing F001 and F003 are assembled into the Booster before installing the oven.

—

Remove anything loose from the oven before moving.

—

Two people should pick up Arc from the lifting points (see Arc manual).

—

Never lift Arc on your own.

—

Do not use the mouth of the oven as a lifting point.

—

Align Arc's feet with the highlighted recesses. Ensure the feet are fully aligned before moving on.

—

*Note oven mouth should face Booster front.

Step 9

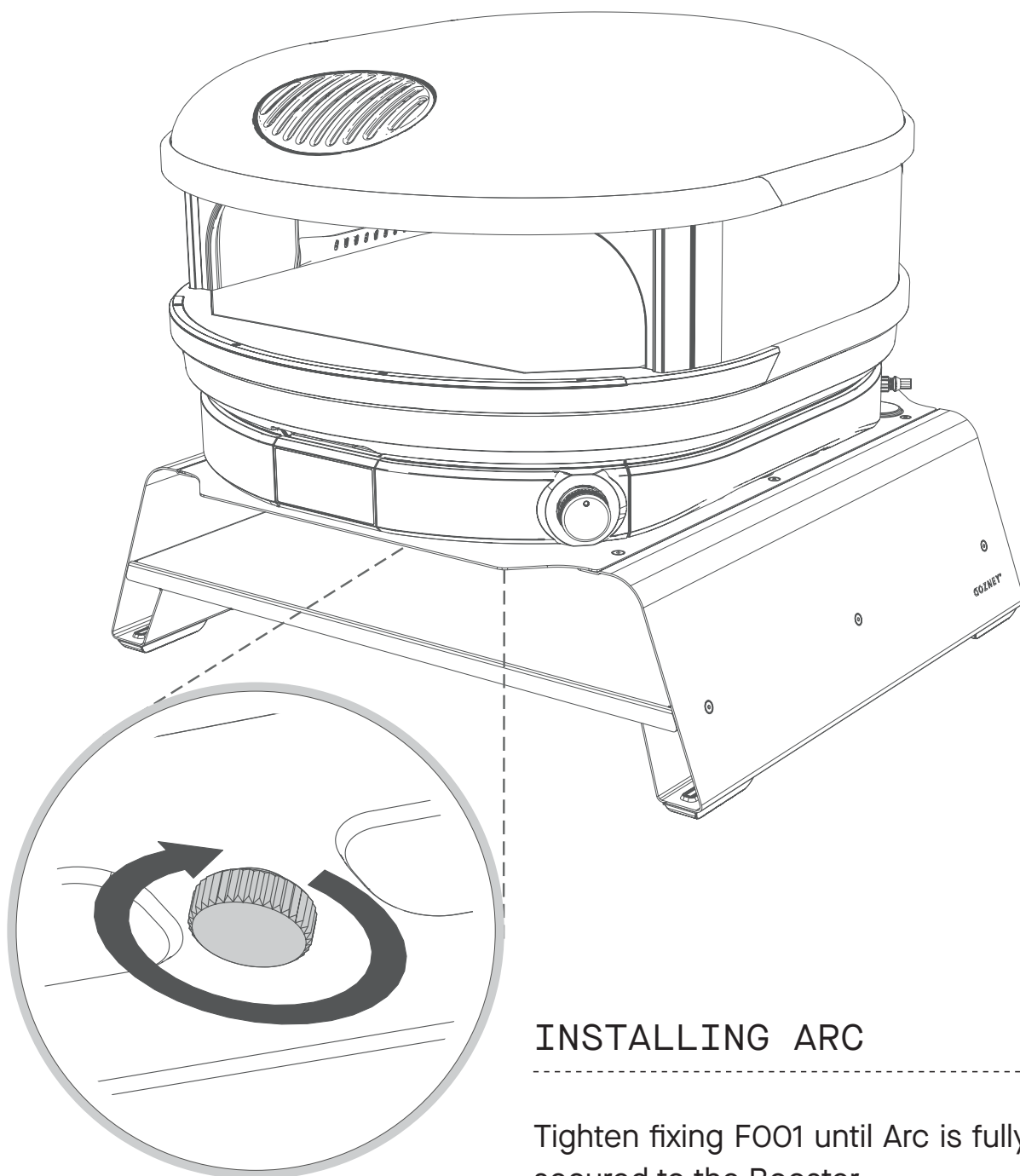

INSTALLING ARC

Tighten fixing F001 until Arc is fully secured to the Booster.

—
Be careful not to over tighten as it can damage the Booster.

—
Never use Arc without it being secured to the Booster by F001.

Dieser Abschnitt behandelt sicherheitskritische Informationen im Zusammenhang mit der Verwendung des Boosters und des Arc-Ofens.

1

Hinweise und Warnungen

Hinweise und Warnungen

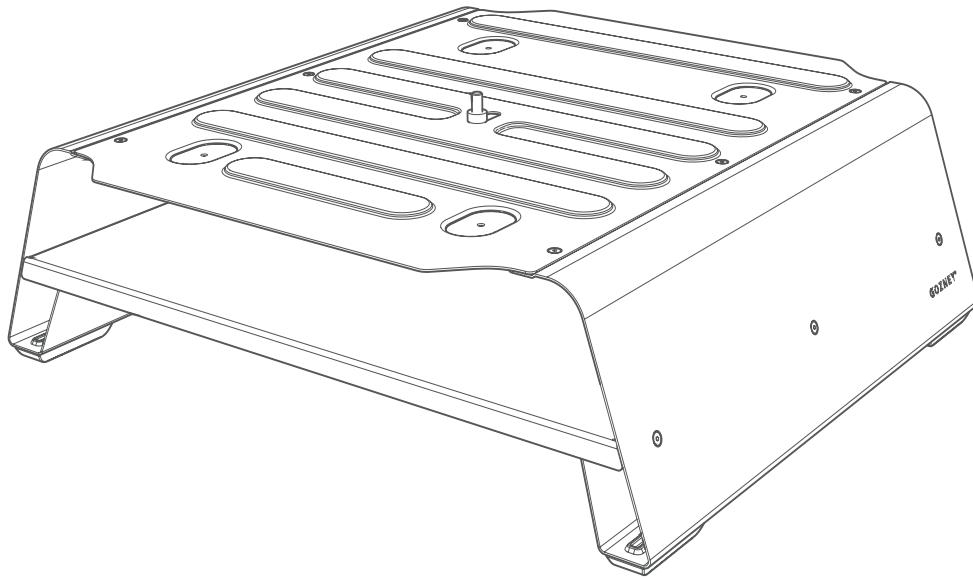

Vergewissern Sie sich, dass Sie die Vorsichtshinweise und Warnungen in der mit dem Ofen gelieferten Arc-Bedienungsanleitung vollständig gelesen und verstanden haben und diese befolgen.

Versuchen Sie niemals, den Ofen zu bewegen, wenn er noch warm ist, sondern warten Sie, bis er vollständig abgekühlt ist.

Wenn Sie den Ofen auf dem Booster bewegen, verwenden Sie immer die Hebe­punkte des Ofens, nicht den Booster oder die Ablageplatte.

Entfernen Sie alle losen Elemente aus dem Booster und den Ablagen, bevor

Wenn Sie heiße Gegenstände aus dem Backofen auf die Ablageplatte stellen, kann diese beschädigt werden; verwenden Sie geeignete Unterlagen, um Schäden zu vermeiden.

Gasbackofen

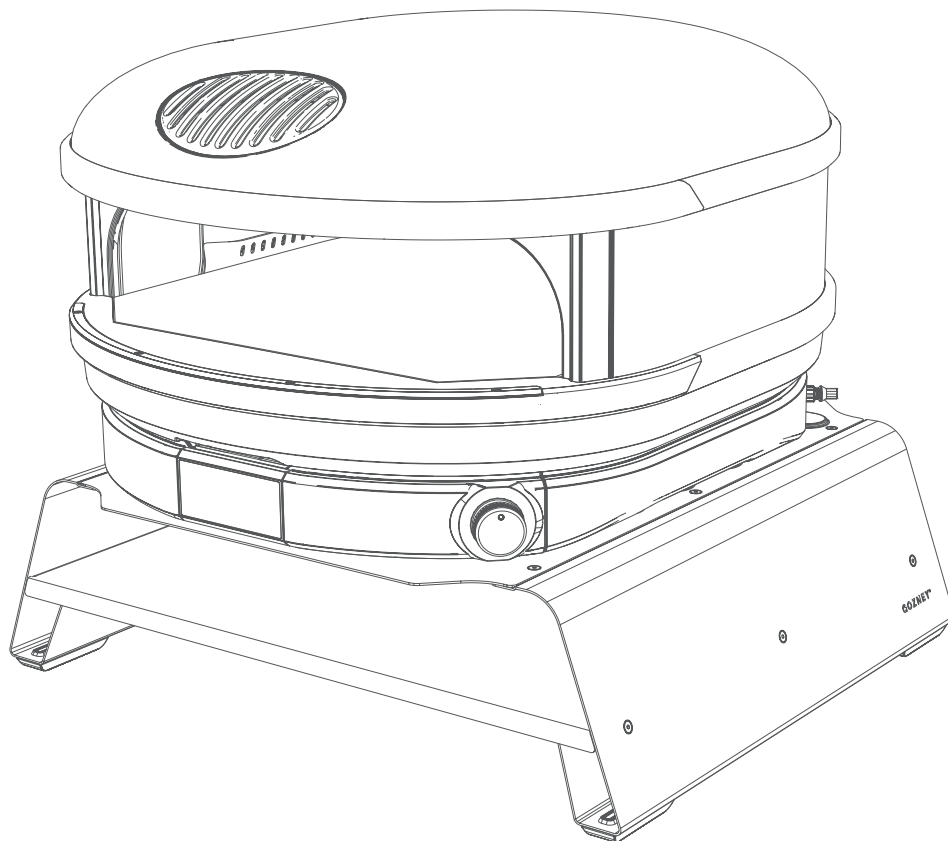

Trennen Sie den Backofen immer von der Gasversorgung, bevor Sie ihn bewegen.

Vergewissern Sie sich, dass Sie einen von Gozney gelieferten Gasanschluss oder einen Anschluss verwenden, der der Norm für bewegliche Gasgeräte (ANSI Z21.69 / CSA 6,16) entspricht, sowie eine Schnelltrennvorrichtung, die den einschlägigen Normen (ANSI Z21.41 / CSA 6,9) entspricht.

Der Gasanschluss und die Schnelltrennvorrichtung oder die dazugehörigen Rohrleitungen sollten niemals dazu verwendet werden, die Bewegung des Geräts einzuschränken.

In diesem Abschnitt werden Aufbau und Installation des Boosters beschrieben.



Aufbau und Installation

Aufbauanleitung

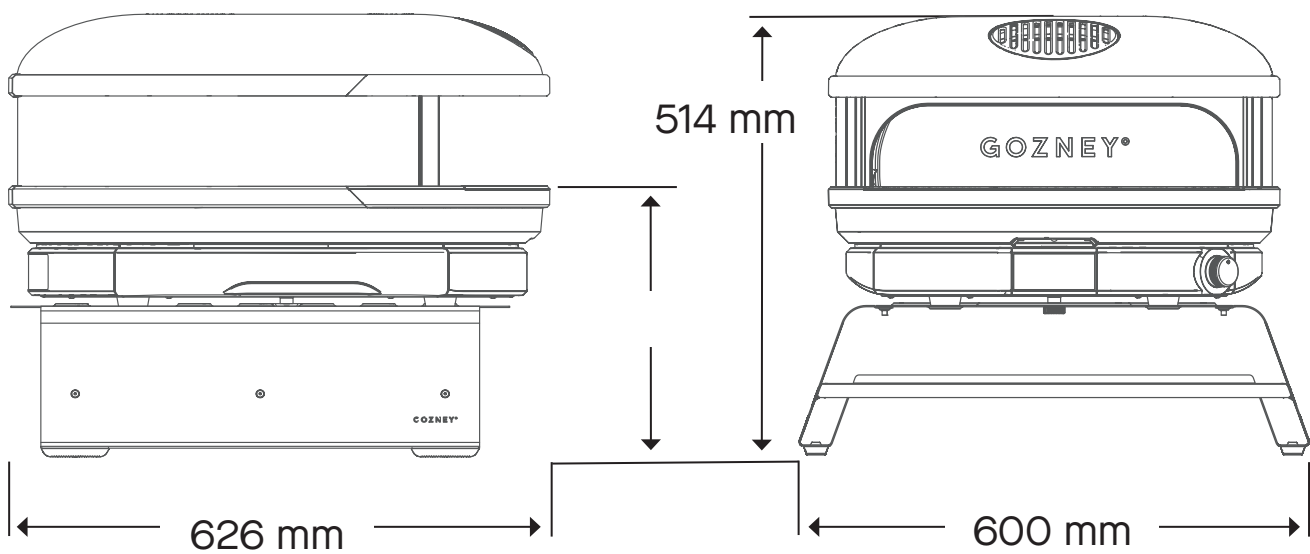

BAUBEREICH

Bauen Sie den Booster in dem Bereich auf, in dem Sie den Arc positionieren möchten.

—
Stellen Sie sicher, dass die Oberfläche stabil und eben ist und das Gewicht des Ofens tragen kann.

—
Legen Sie keines der Teile auf eine scheuernde Oberfläche und vermeiden Sie es, die Lackierung der Metallteile zu beschädigen.

Lieferumfang

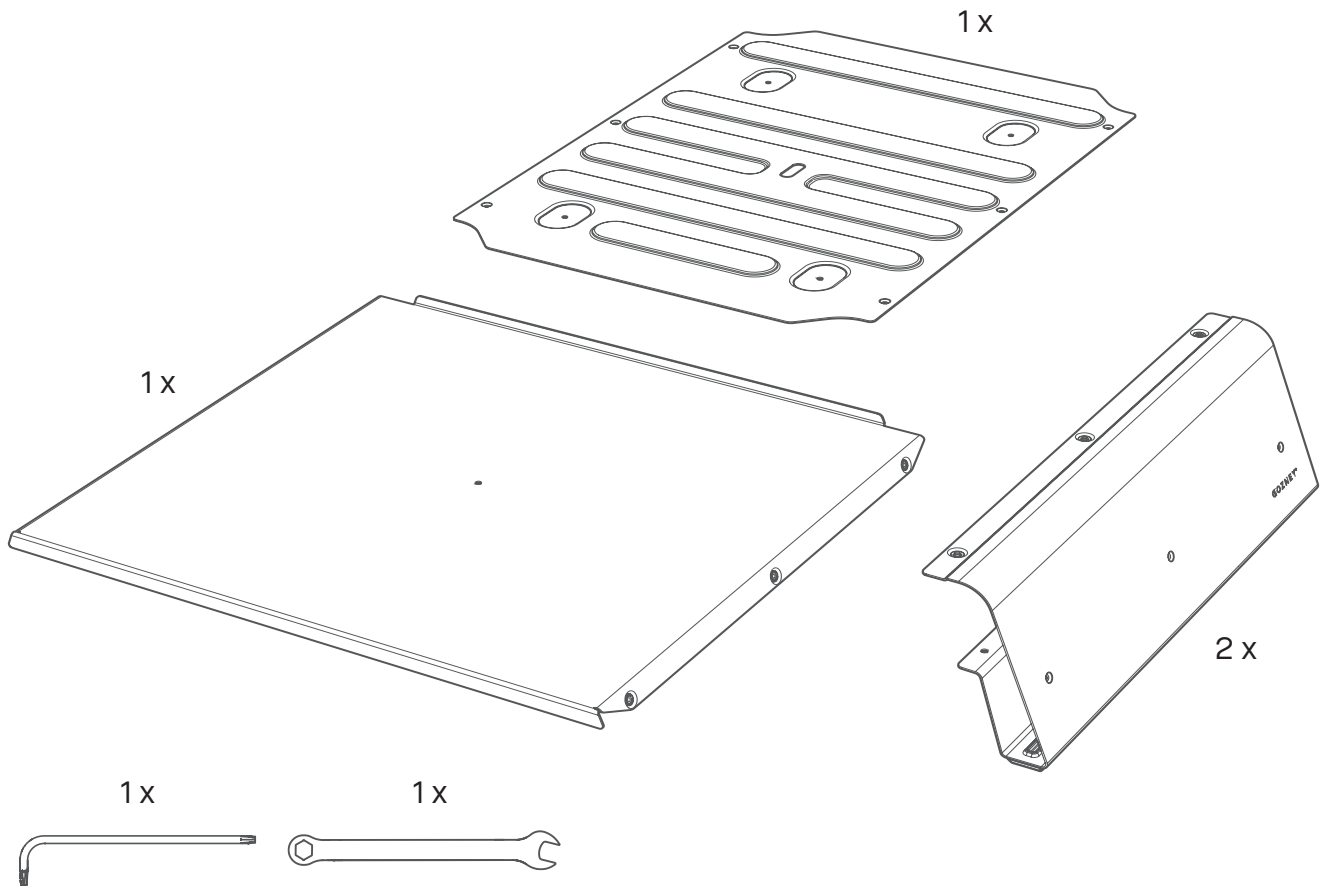

MASSTAB 1:1

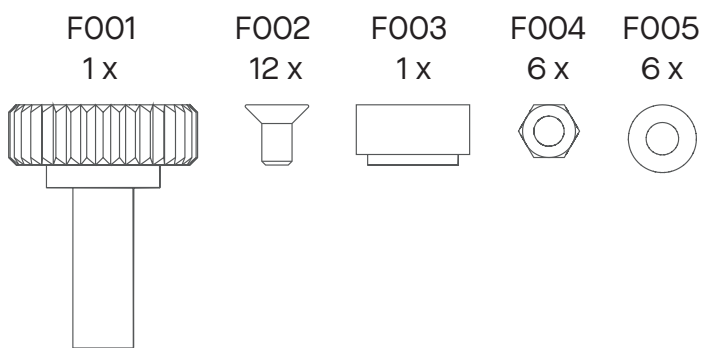

Schritt 1

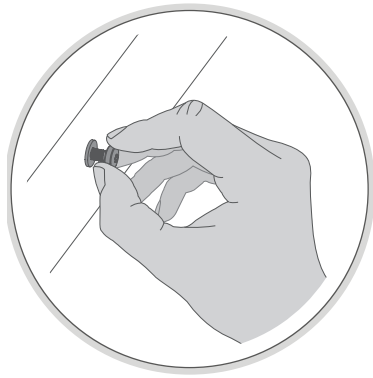

BEFESTIGUNGEN

Wir empfehlen, die Schrauben und Muttern nicht voll festzuziehen, bis der Booster montiert wurde.

—
Dies erleichtert die Ausrichtung der nachfolgenden Befestigungen. Ziehen Sie sie in Schritt 6 vollständig fest.



F002
3x

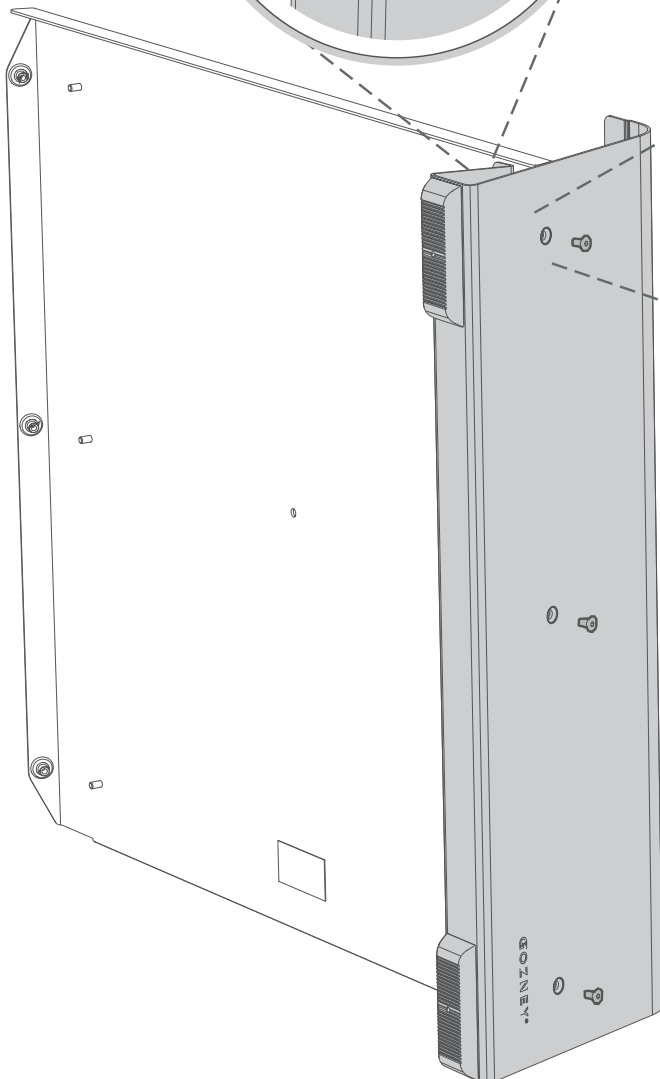
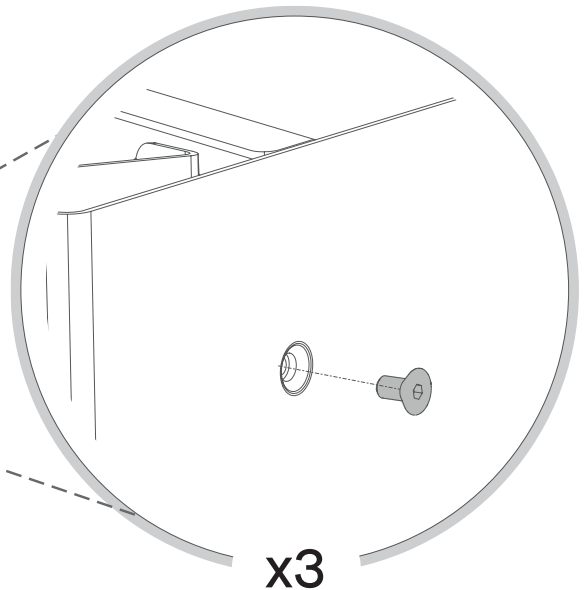
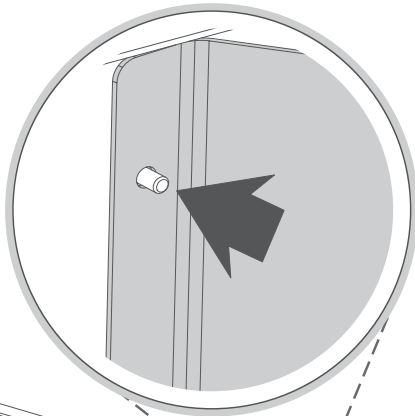

Schritt 2



F005
3x

F004
3x

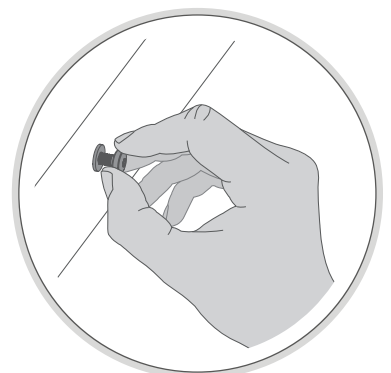
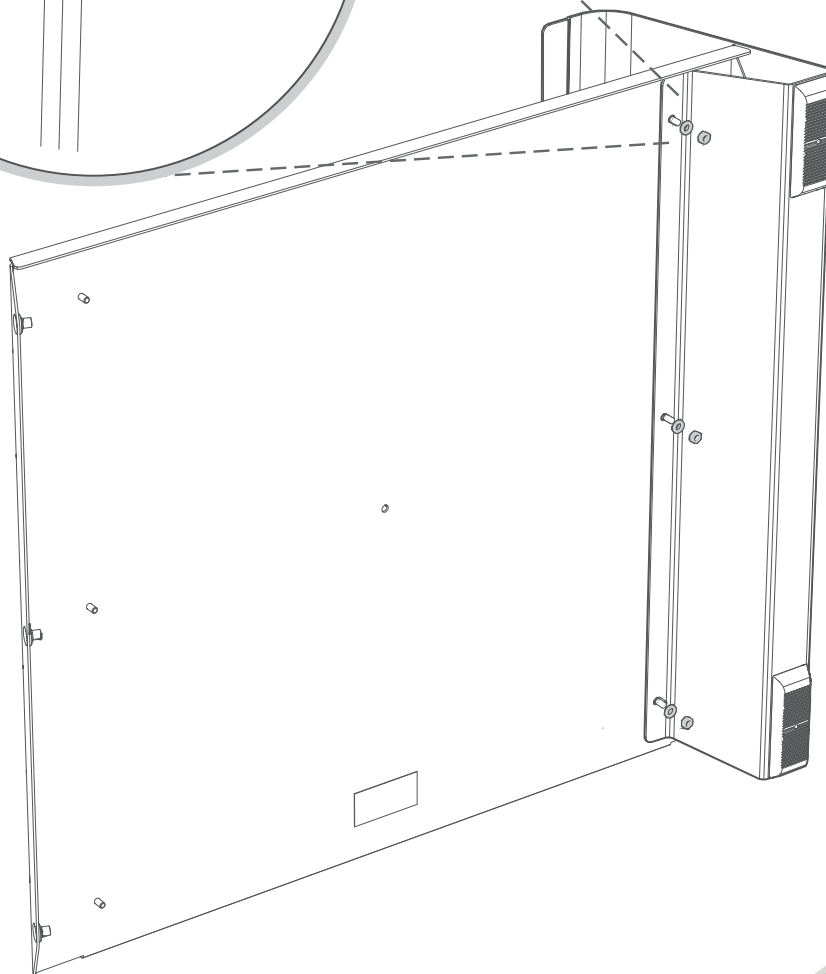
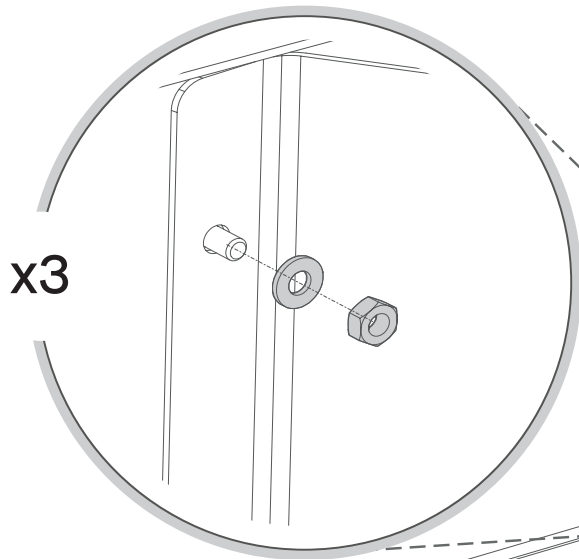

Schritt 3



F002
3x

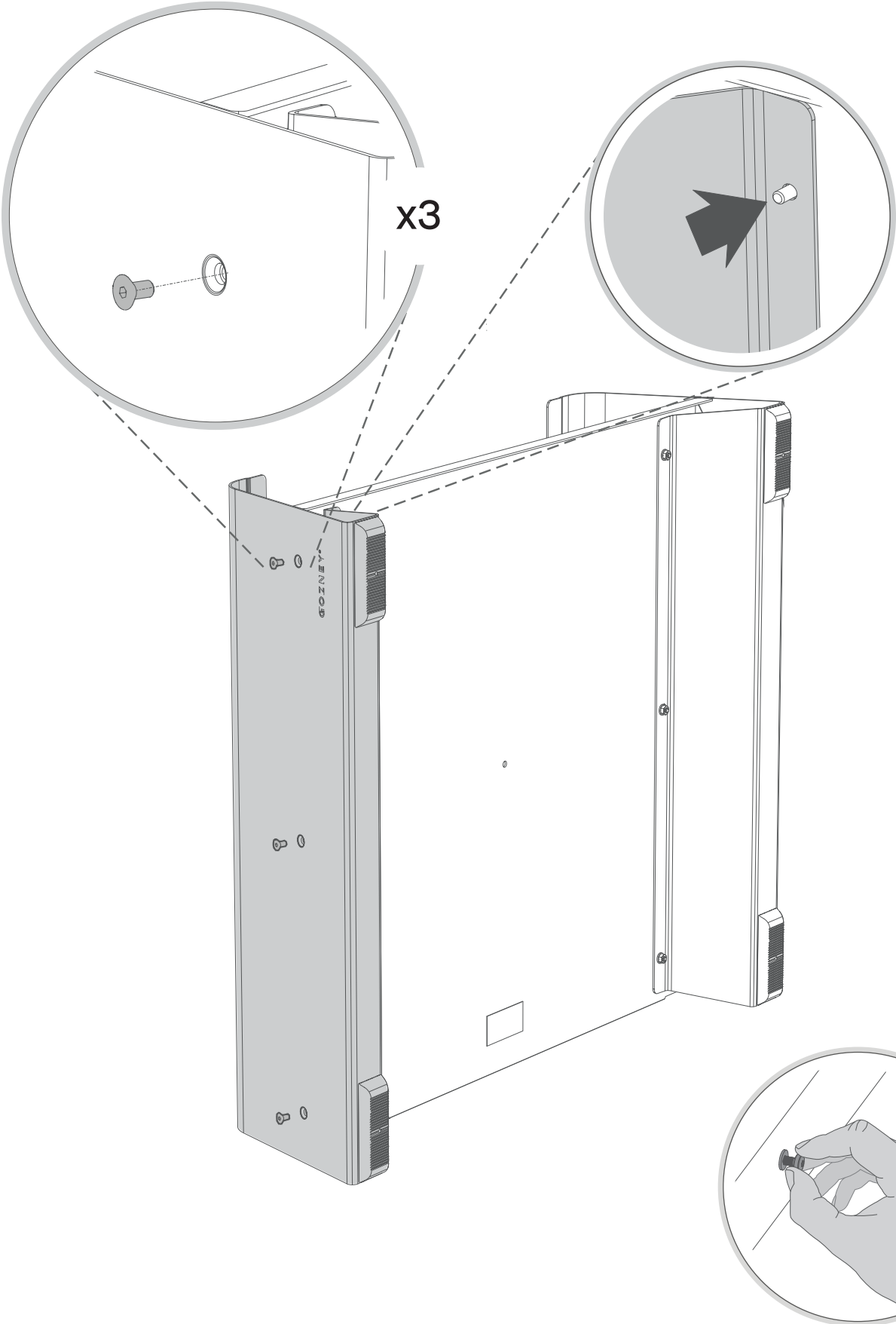

Schritt 4



F005
3x

F004
3x

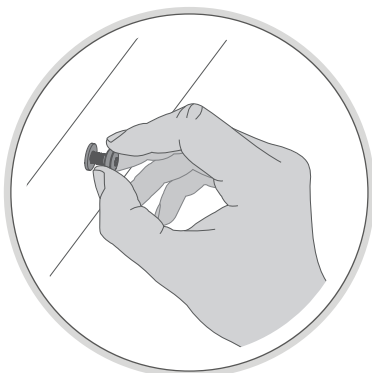
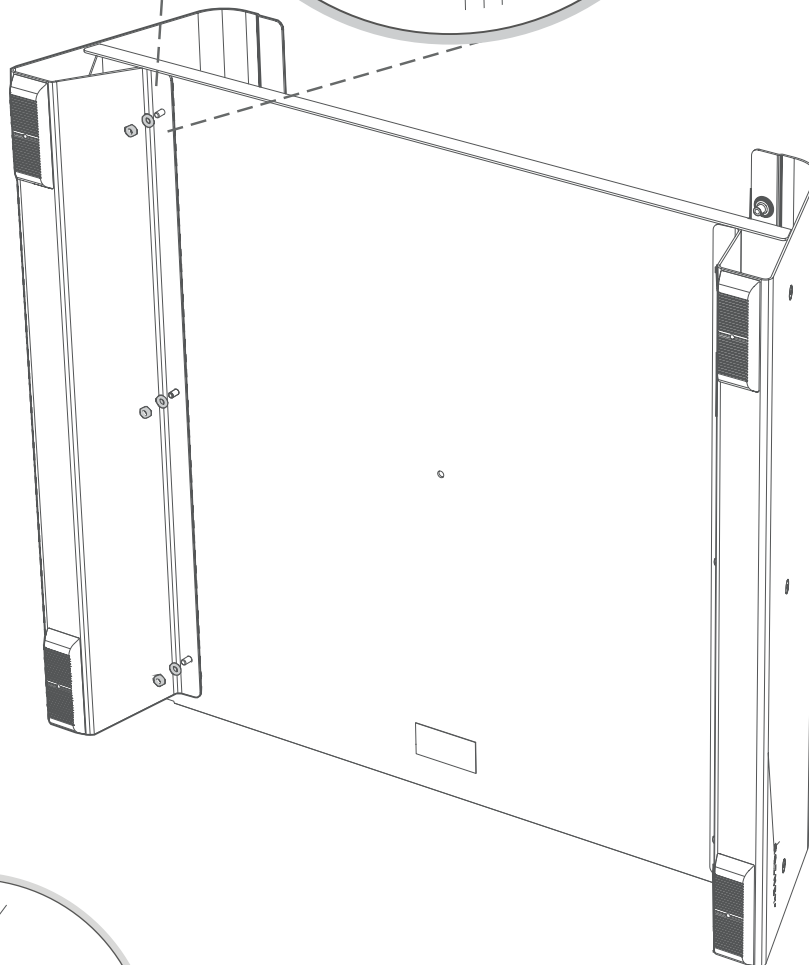
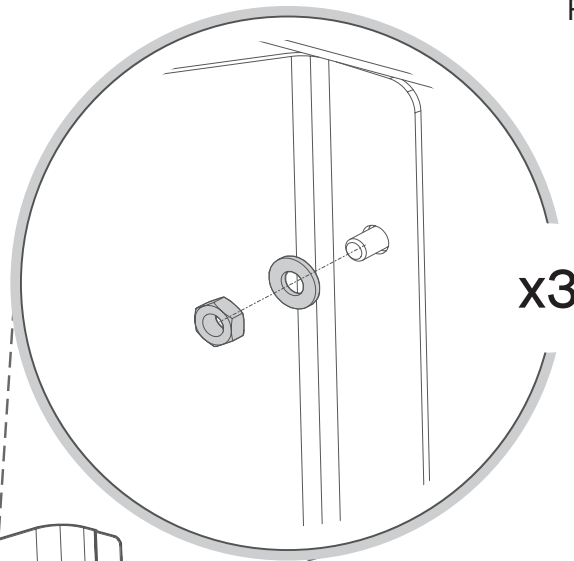

Schritt 5



F002
6 x

x 6

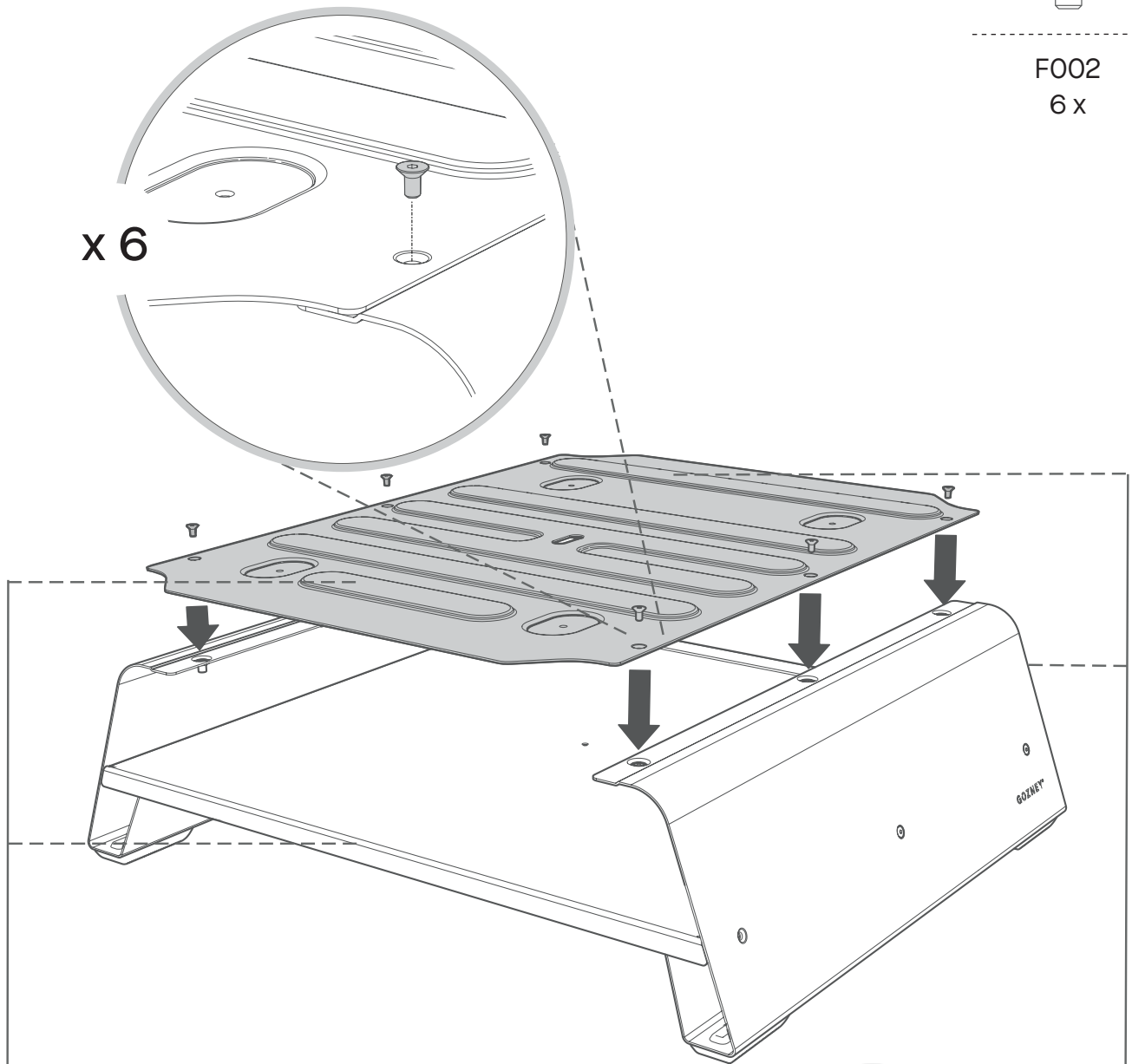

Schritt 6

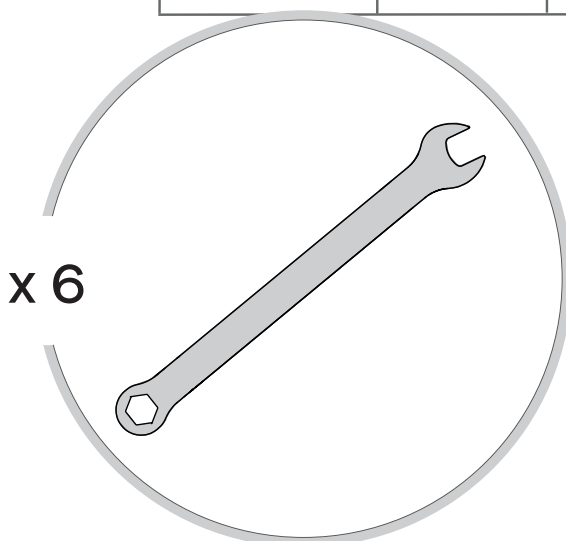
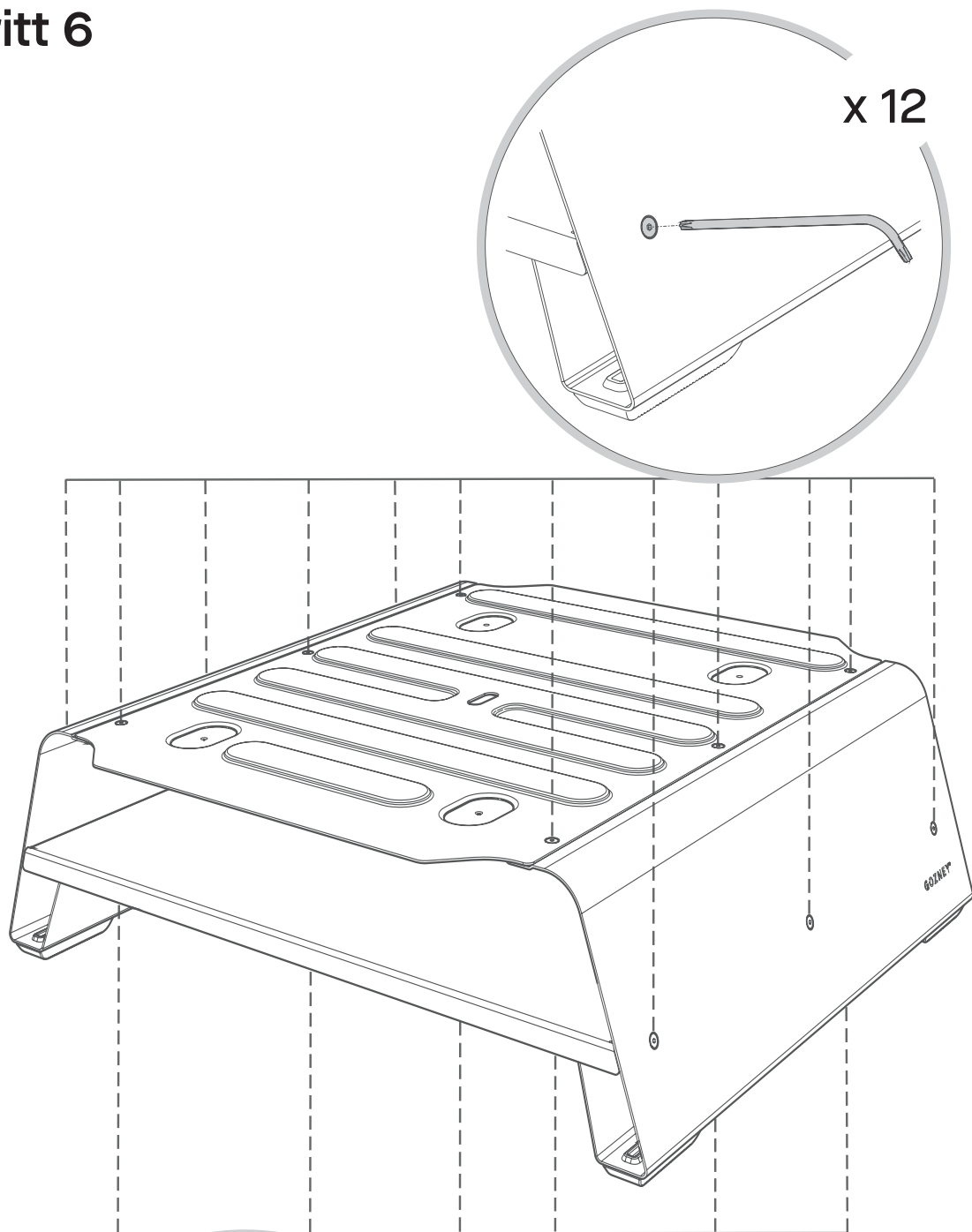

BEFESTIGUNGEN

Ziehen Sie alle Befestigungen des Boosters fest, wobei Sie darauf achten, dass Sie sie nicht zu fest anziehen.

Schritt 7

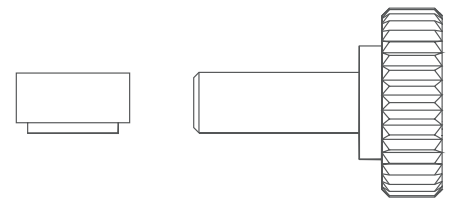

F003
1 x

F001
1 x

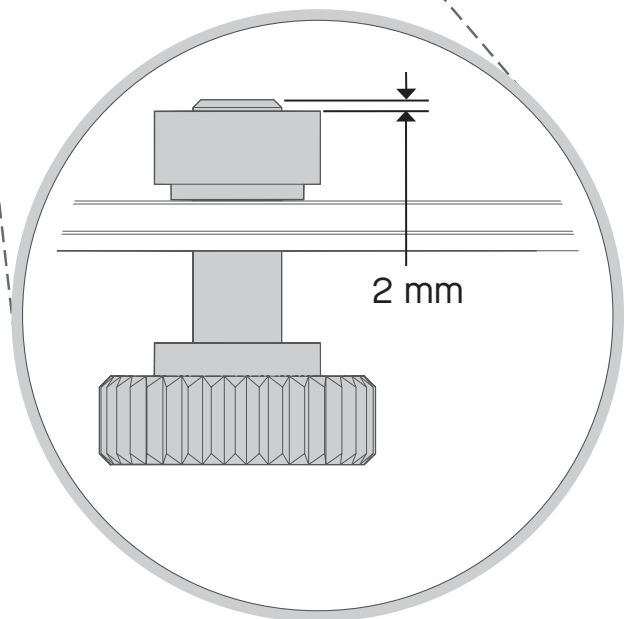
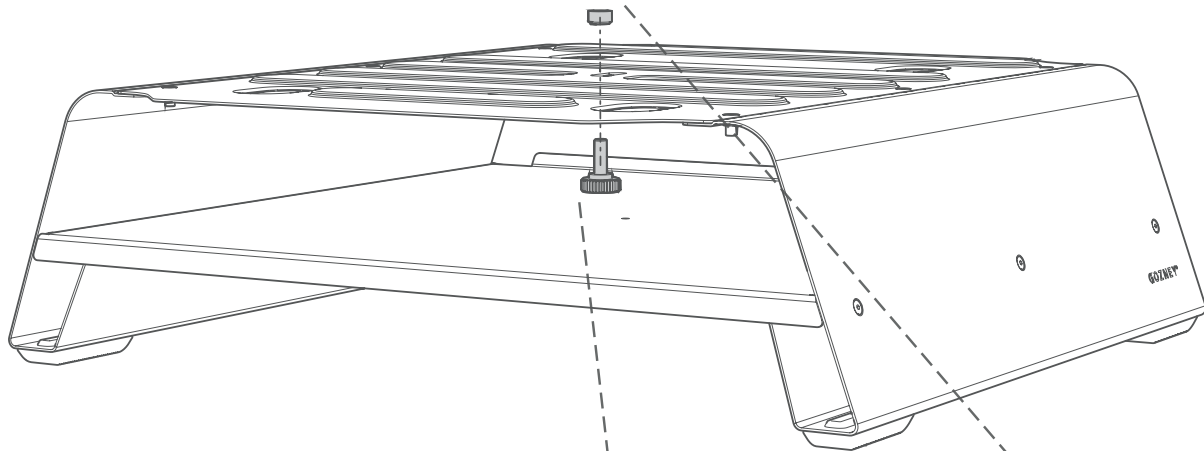

INSTALLATION DES ARC

Montieren Sie vor der Installation des Arc die Befestigungen F001 und F003 oben am Gestell.

Ziehen Sie diese beiden Befestigungen nicht vollständig an. Es sollte nicht mehr als 2 mm an Gewinde sichtbar sein.

Schritt 8

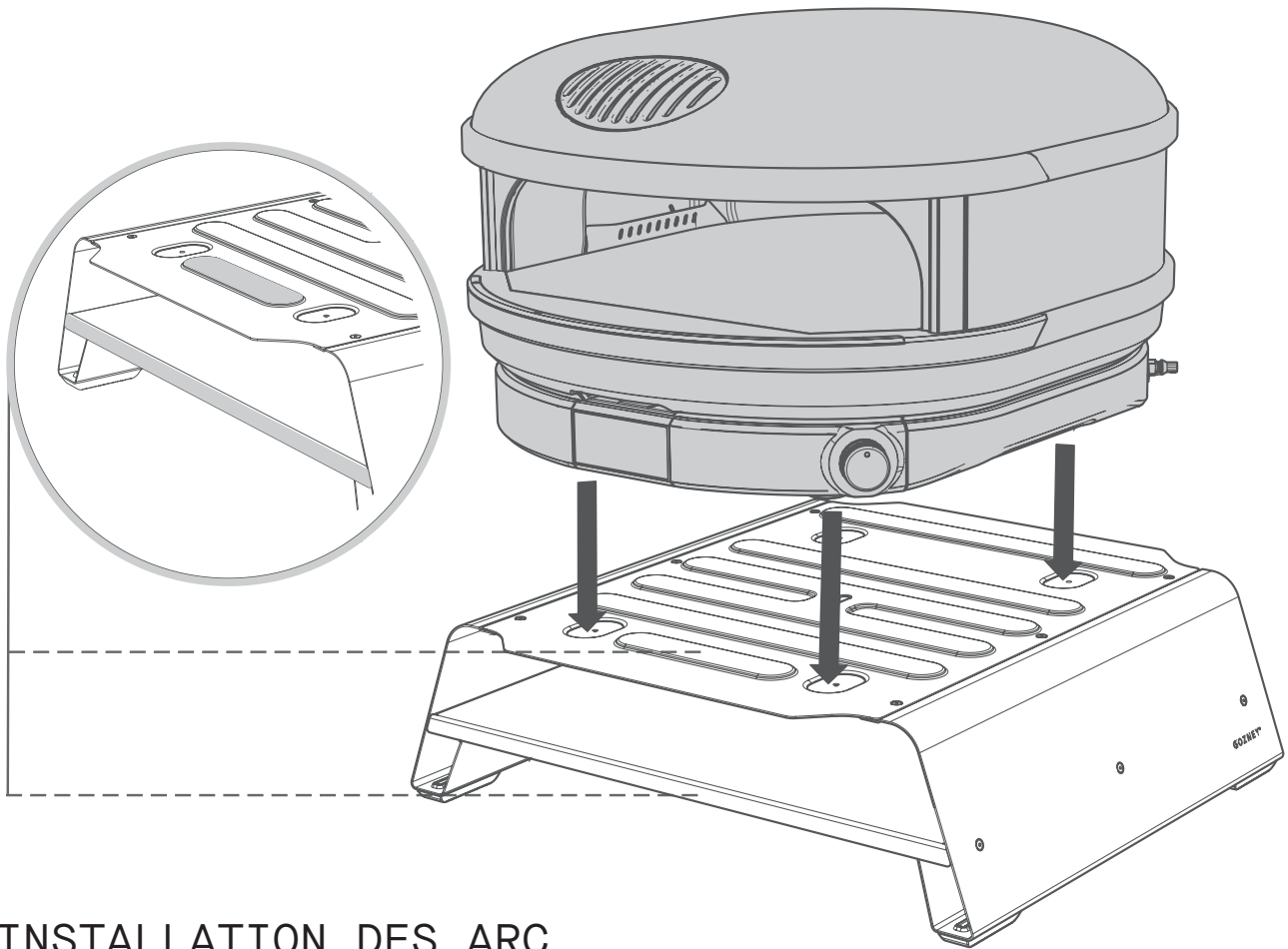

INSTALLATION DES ARC

Vergewissern Sie sich, dass die Befestigungen F001 und F003 im Gestell montiert sind, bevor Sie den Ofen montieren.

—

Entfernen Sie alle losen Elemente am Ofen, bevor Sie ihn bewegen.

—

Der Arc sollte von zwei Personen an den Hebepunkten angehoben werden (siehe Arc-Bedienungsanleitung).

—

Heben Sie den Arc nie alleine an.

—

Verwenden Sie die Öffnung des Ofens nicht als Hebepunkt.

—

Richten Sie die Füße des Arc an den markierten Aussparungen aus. Stellen Sie sicher, dass die Füße vollständig ausgerichtet sind, bevor Sie fortfahren.

—

* Beachten Sie, dass die Öffnung des Ofens zur Vorderseite des Booster zeigen muss.

Schritt 9

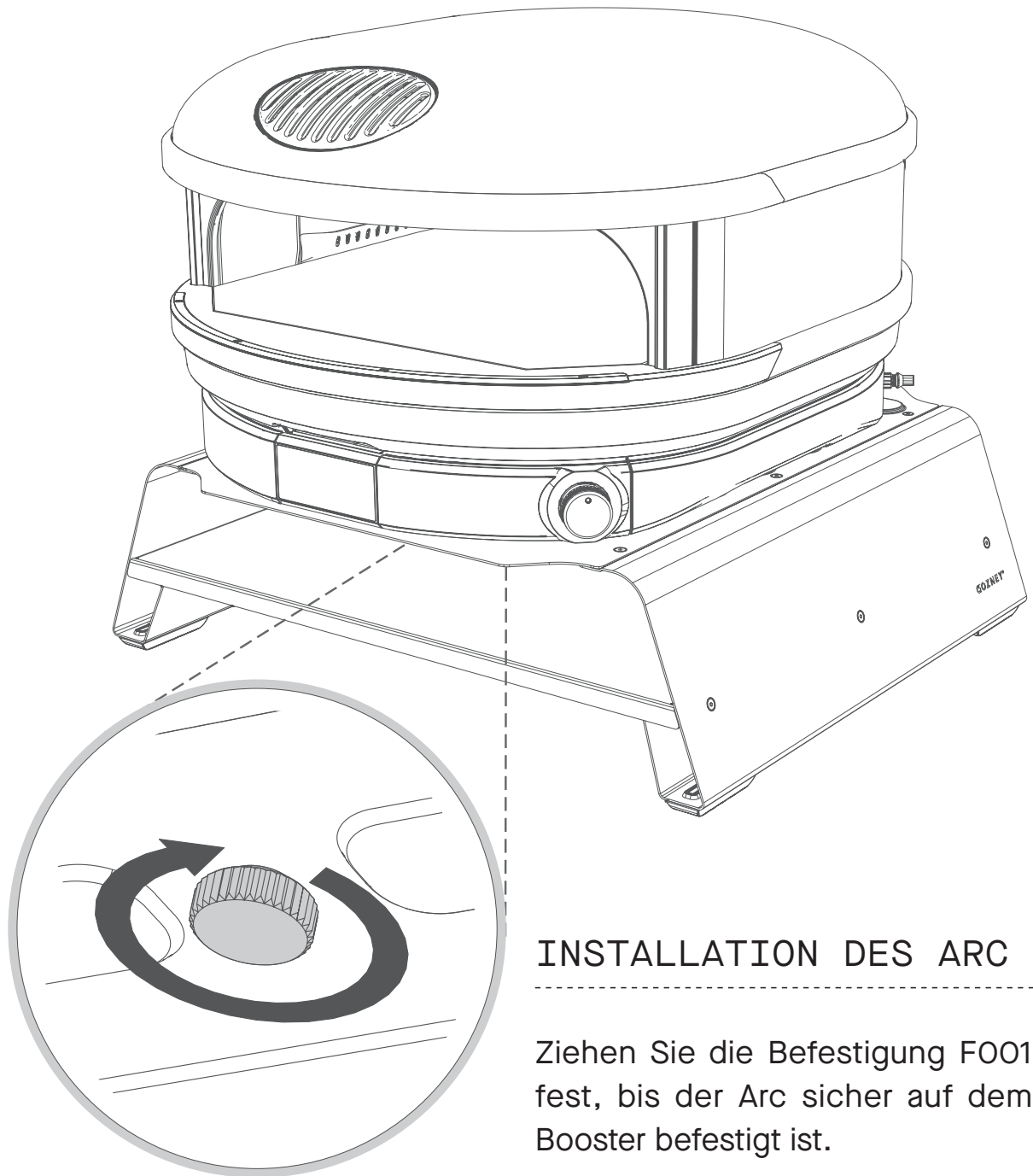

INSTALLATION DES ARC

Ziehen Sie die Befestigung F001 fest, bis der Arc sicher auf dem Booster befestigt ist.

—
Achten Sie darauf, dass Sie sie nicht zu fest anziehen, da dies den Booster beschädigen kann.

—
Verwenden Sie den Arc niemals, wenn dieser nicht mit F001 auf dem Booster befestigt ist.

Esta sección contiene información importante relacionada con el uso del Booster y el horno Arc.



Precauciones y advertencias

Precauciones y advertencias

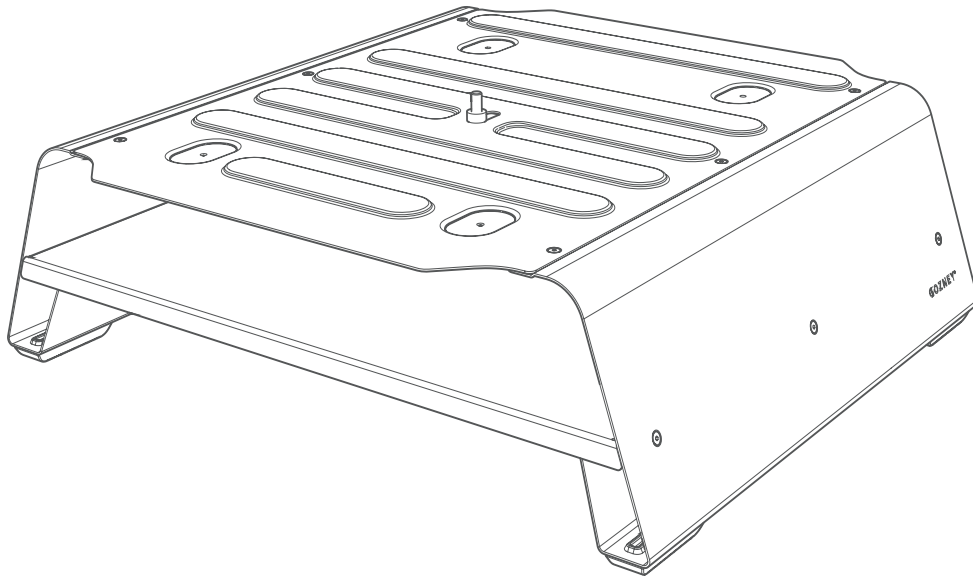

Asegúrese de haber leído, entendido y seguido todas las precauciones y advertencias del Manual del usuario del Arc suministrado con el horno.

No intente nunca mover el horno mientras esté caliente; espere a que se enfríe completamente.

Para mover el horno cuando esté en el Booster, levántelo siempre utilizando los puntos de agarre, no el Booster o los estantes.

Retire cualquier objeto suelto del Booster y sus estantes antes de moverlo.

Colocar objetos calientes recién salidos del horno en el estante puede dañar el recubrimiento; utilice una protección adecuada para evitar el deterioro.

Horno de gas

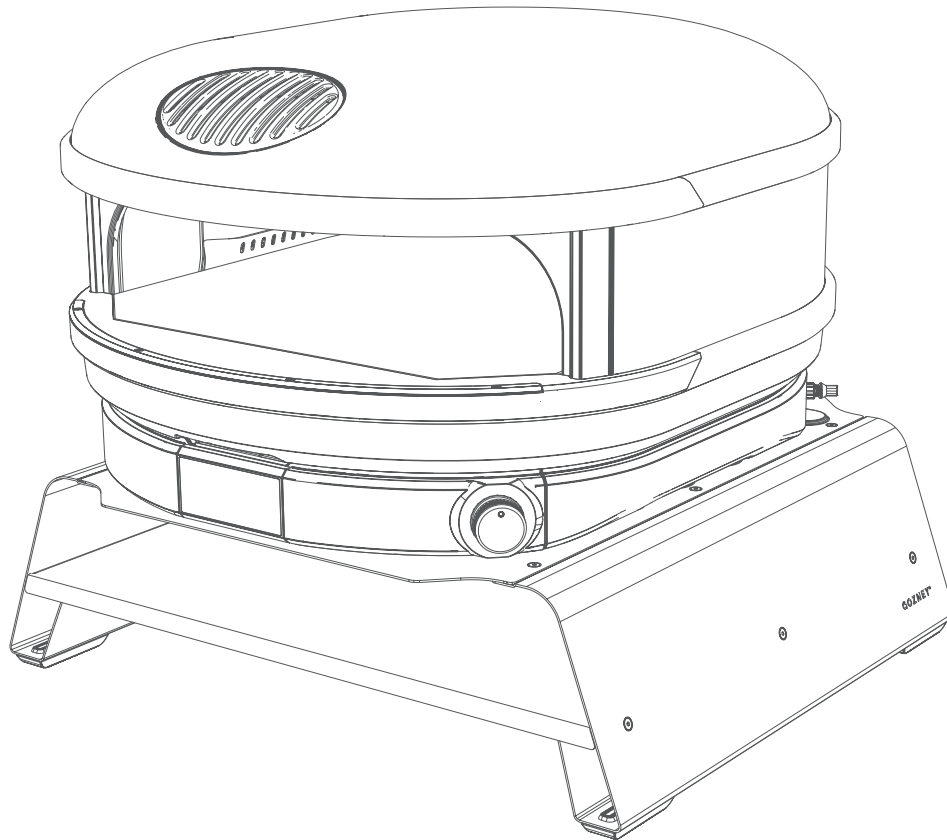

Desconecte siempre el horno del suministro de gas antes de moverlo.

Asegúrese de utilizar un conector de gas suministrado por Gozney o uno que cumpla con la norma para aparatos de gas móviles (ANSI Z21.69 / CSA 6,16), y un dispositivo de desconexión rápida que cumpla con las normas relevantes (ANSI Z21.41 / CSA 6,9).

El conector de gas y el dispositivo de desconexión rápida o el tubo asociado nunca deben utilizarse para limitar el movimiento del aparato.

Esta sección detalla el proceso de montaje y la instalación correcta del Booster.



Montaje e instalación

Manual de montaje

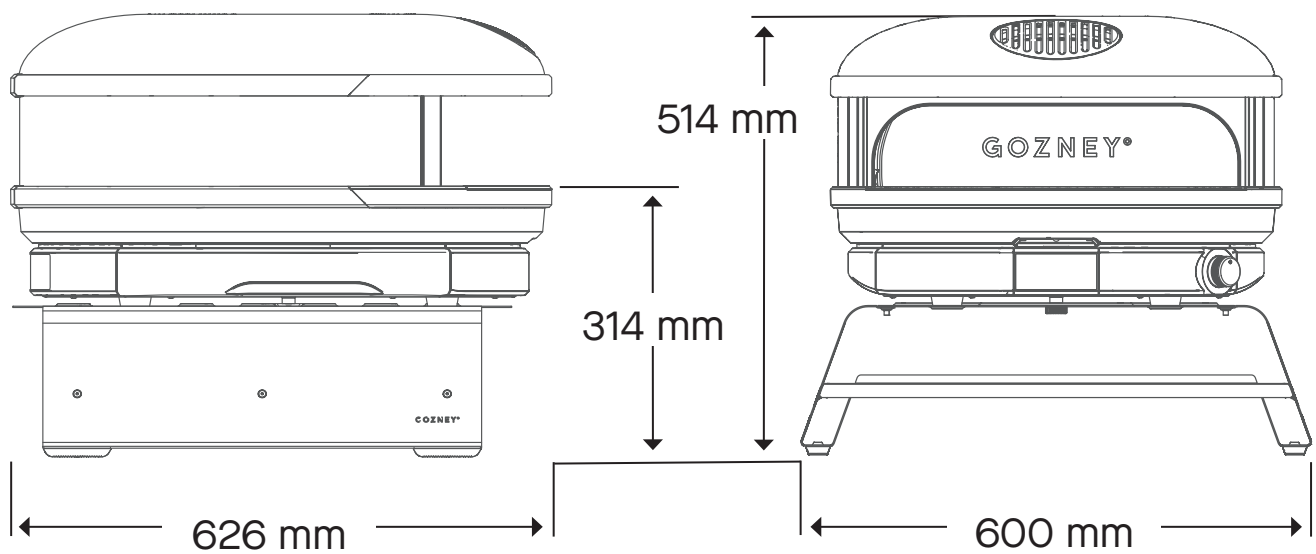

ZONA DE MONTAJE

Monte el Booster en la zona en la que quiera colocar el Arc.

—

Asegúrese de que la superficie sea estable, esté nivelada y pueda soportar el peso del horno.

—

No coloque ninguna de las piezas sobre una superficie abrasiva y tenga cuidado de no dañar la pintura de las piezas metálicas.

Contenido de la caja

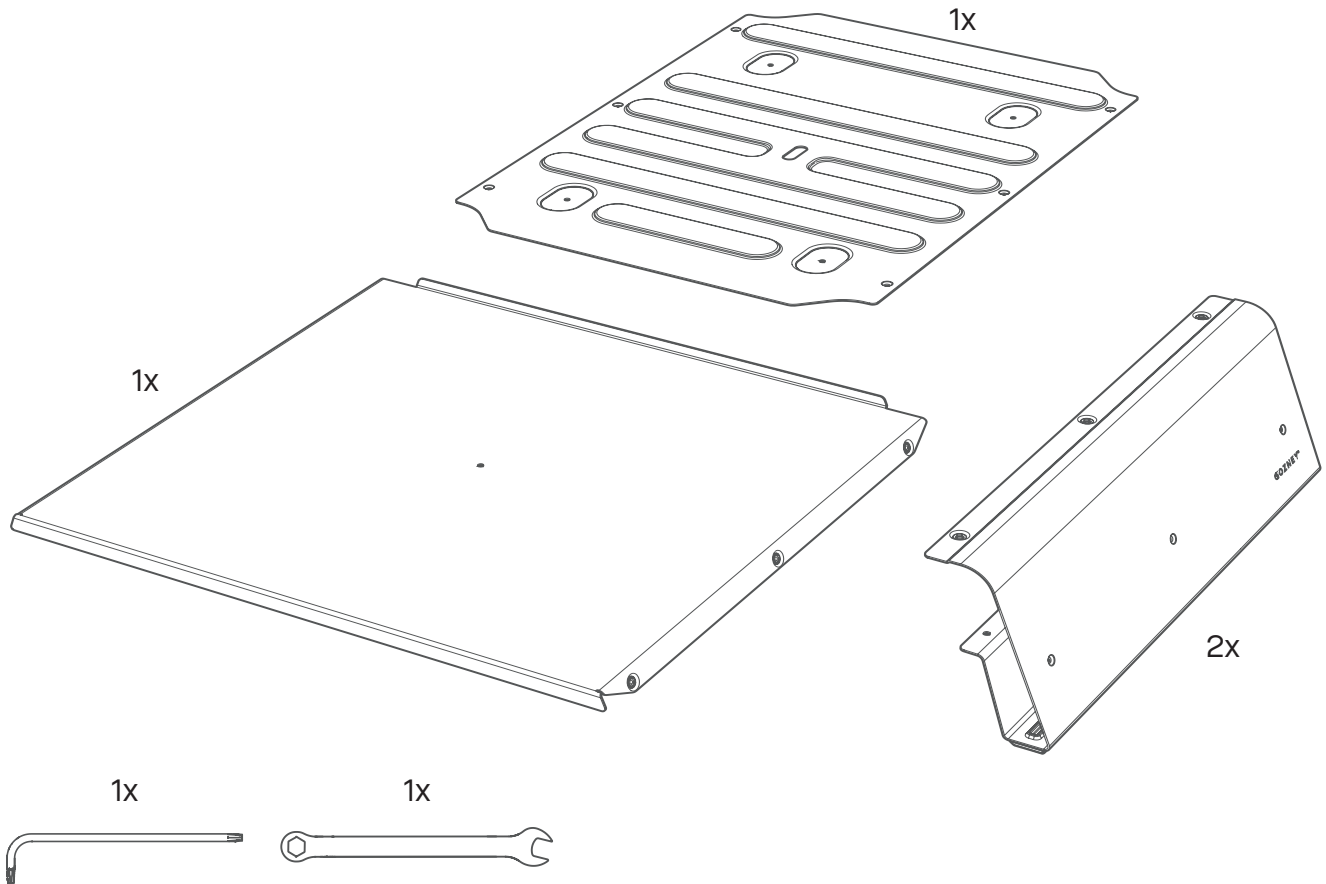

ESCALA 1:1

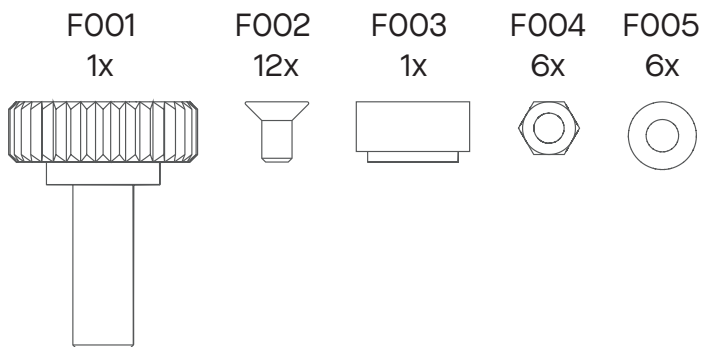

Paso 1

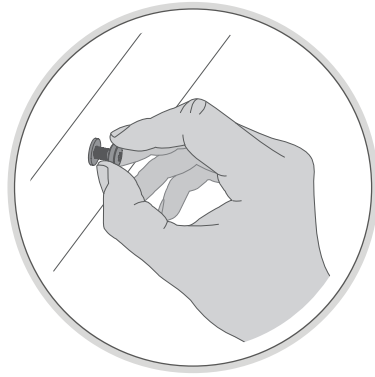

SUJECIONES

Recomendamos no apretar del todo las tuercas y tornillos hasta que se haya terminado de montar el Booster.

—
Esto facilitará la alineación del resto de las fijaciones. Apriételes del todo en el paso 6.

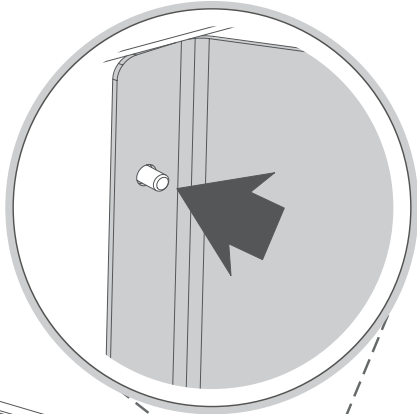

F002
3x

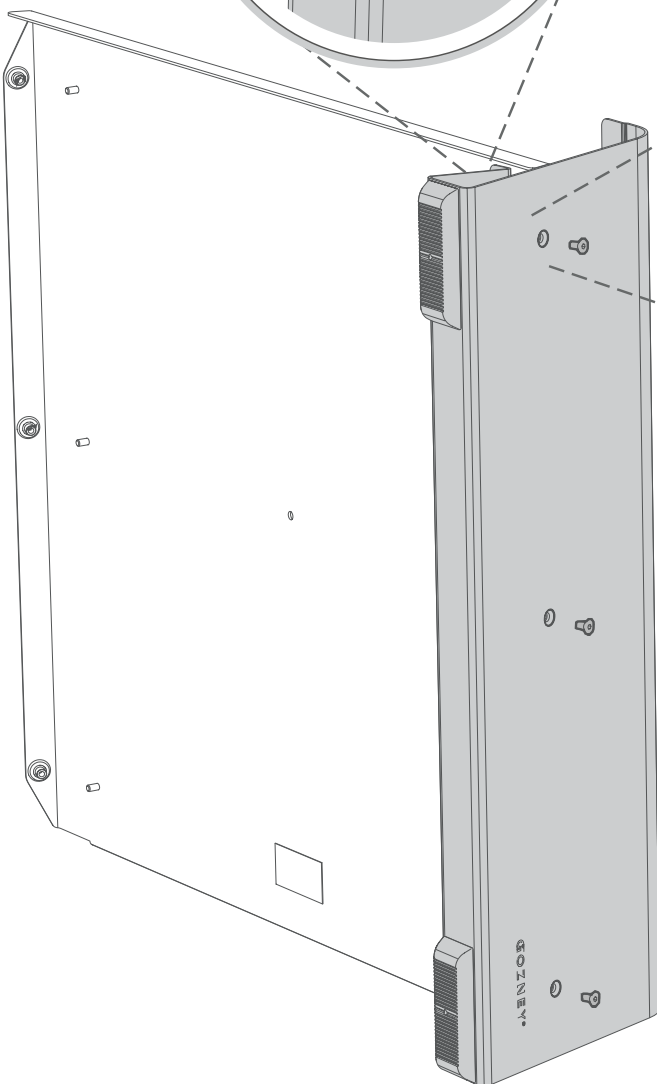
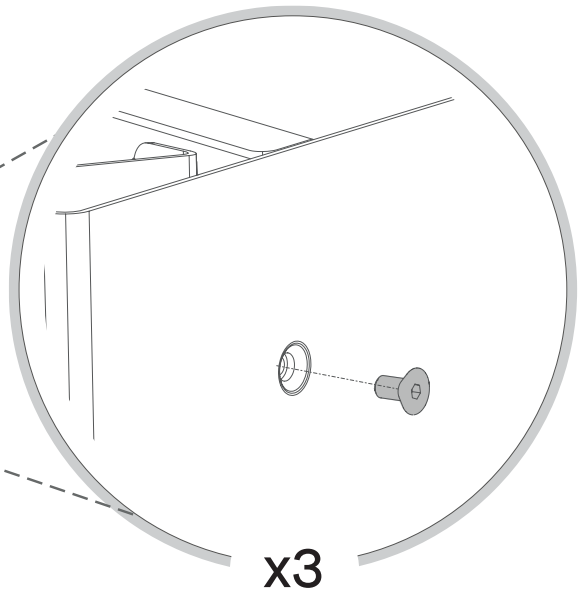

Paso 2



F005
3x

F004
3x

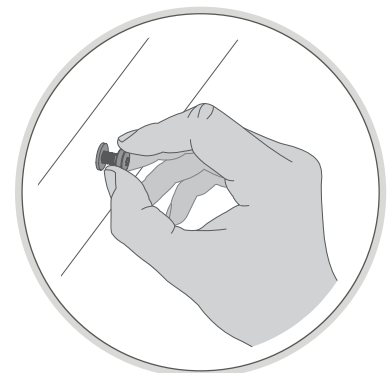
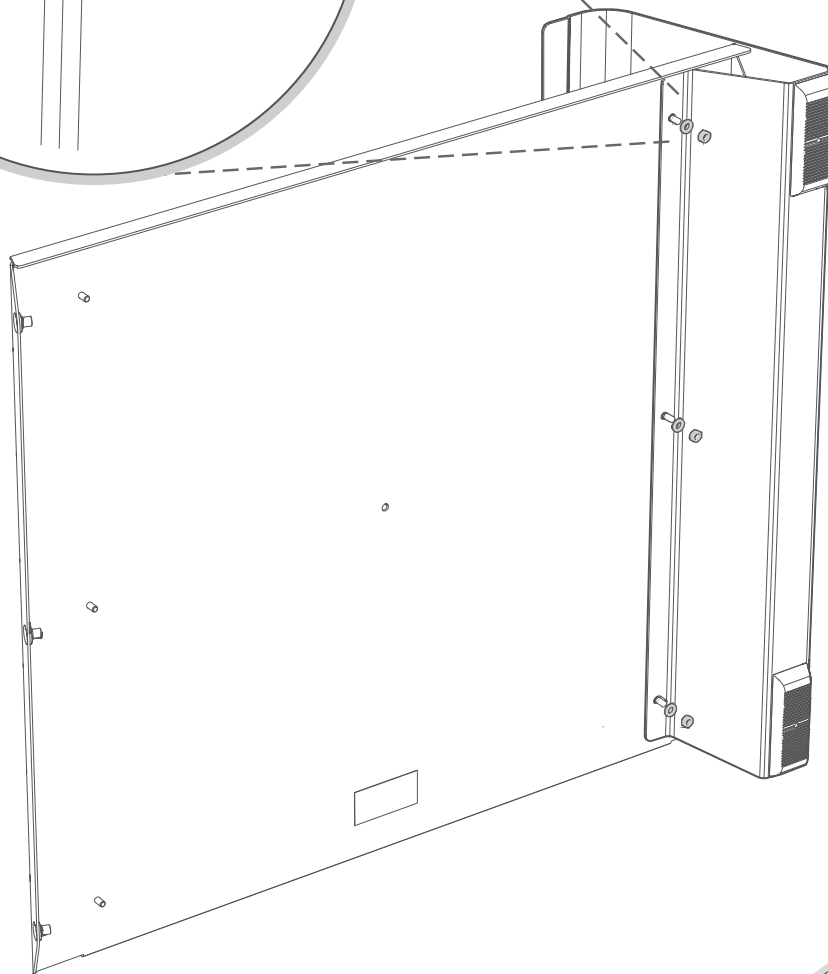
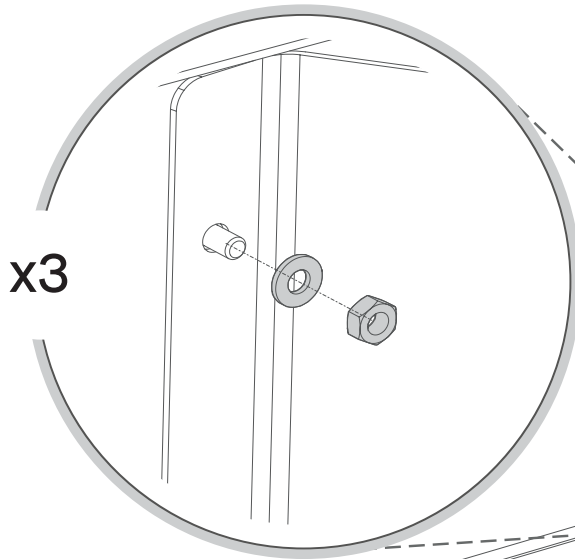

Paso 3



F002
3x

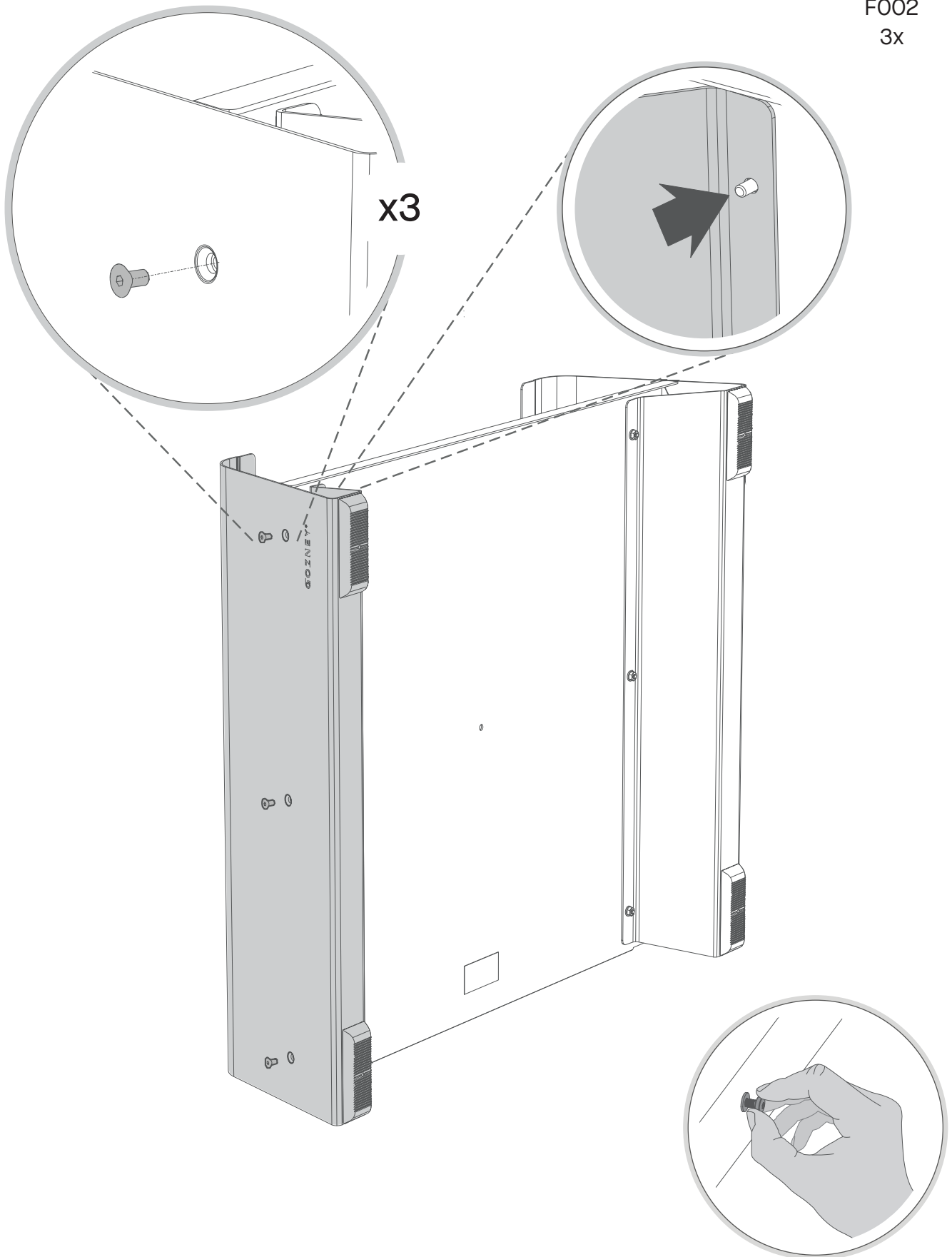

Paso 4



F005
3x

F004
3x

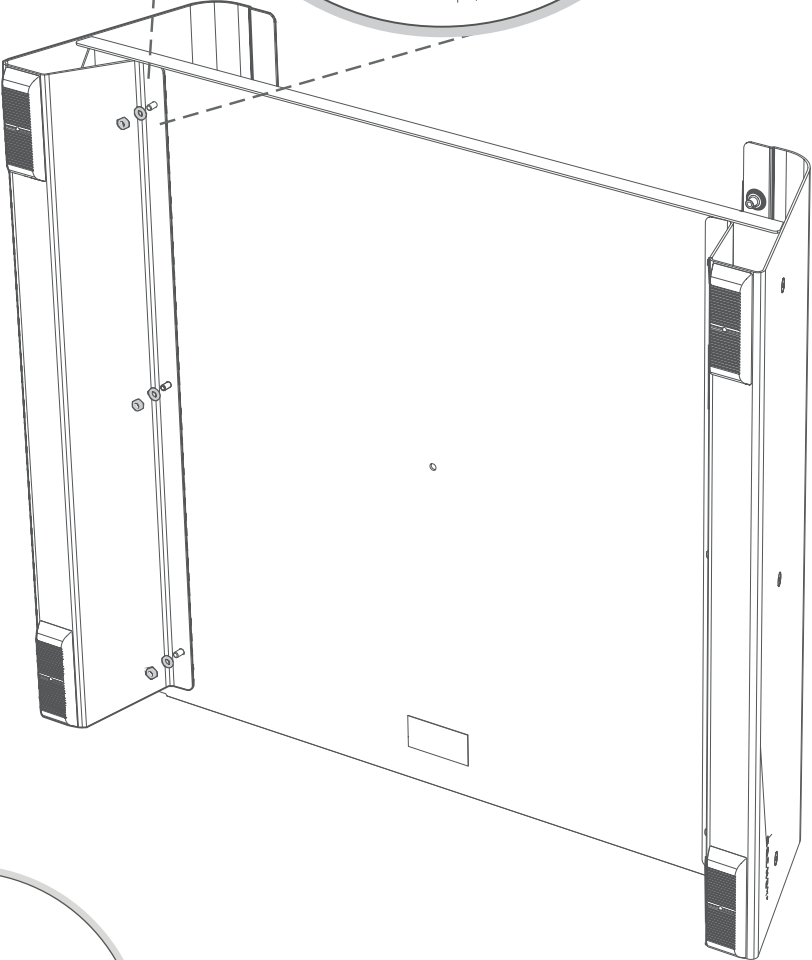
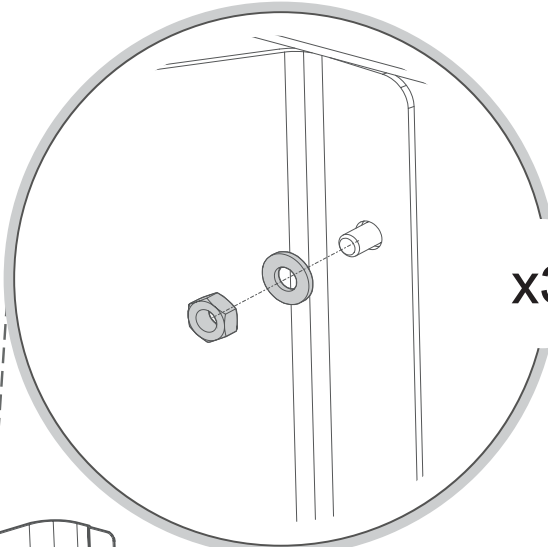

Paso 5



F002
6x

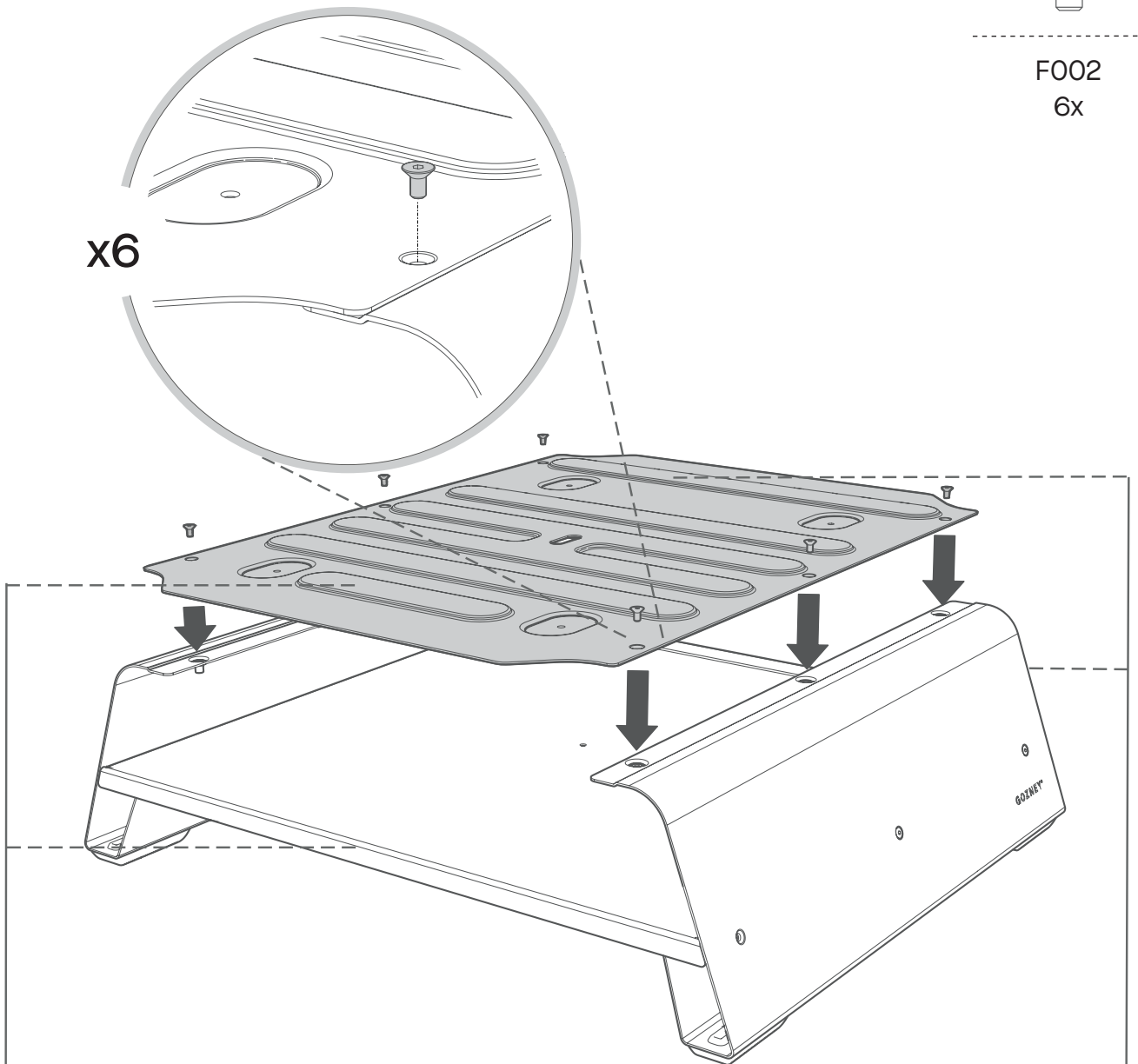

Paso 6

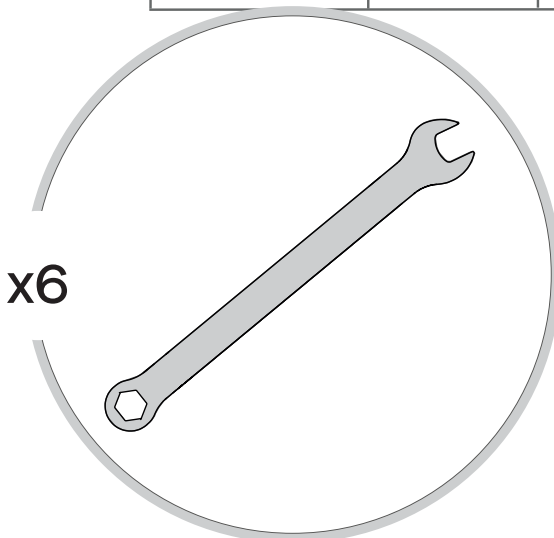
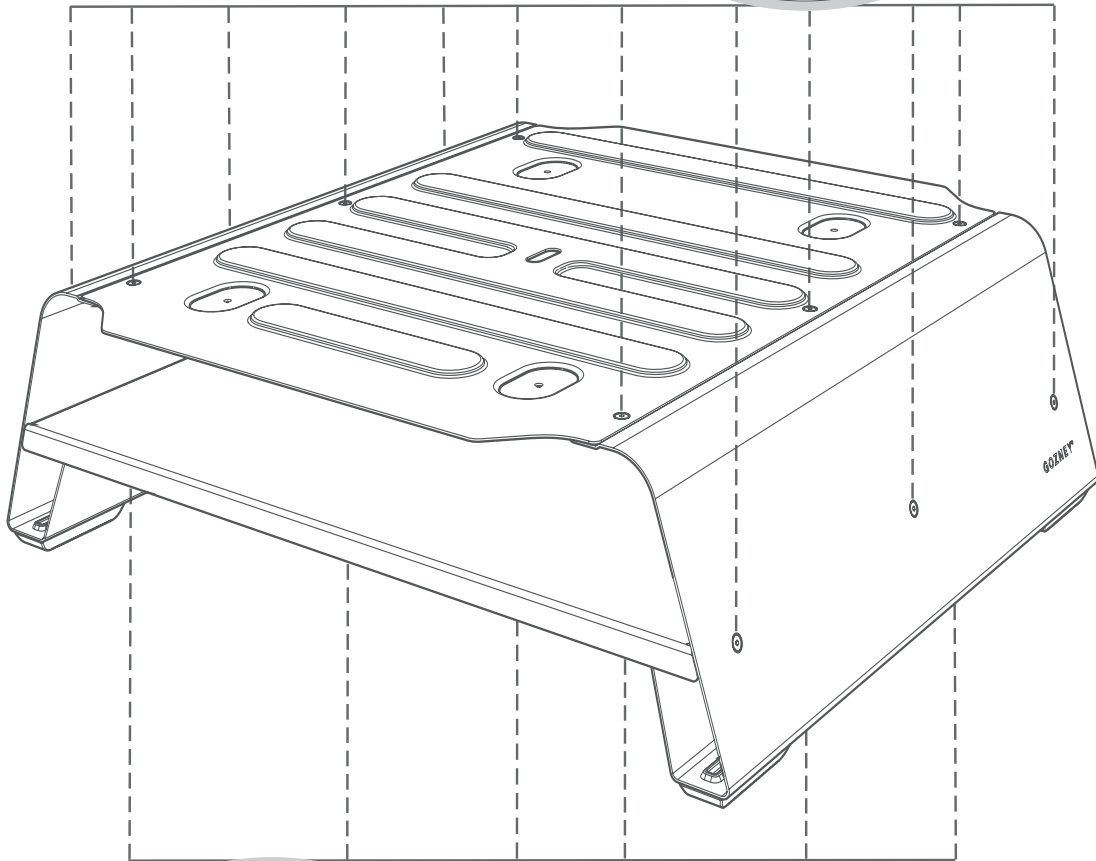
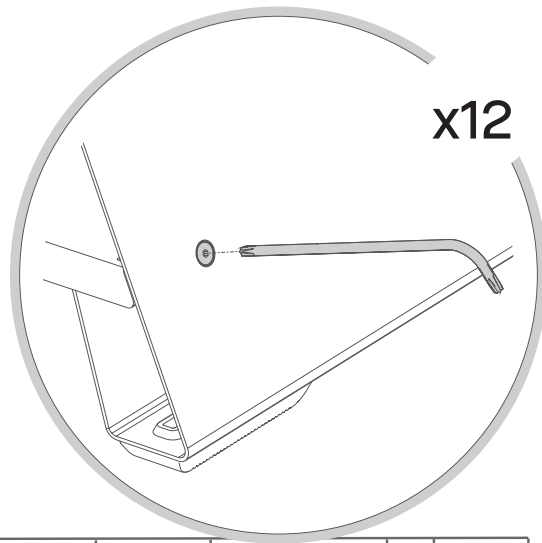

SUJECIONES

Apriete todas las fijaciones del Booster, teniendo cuidado de no apretarlas demasiado.

Paso 7

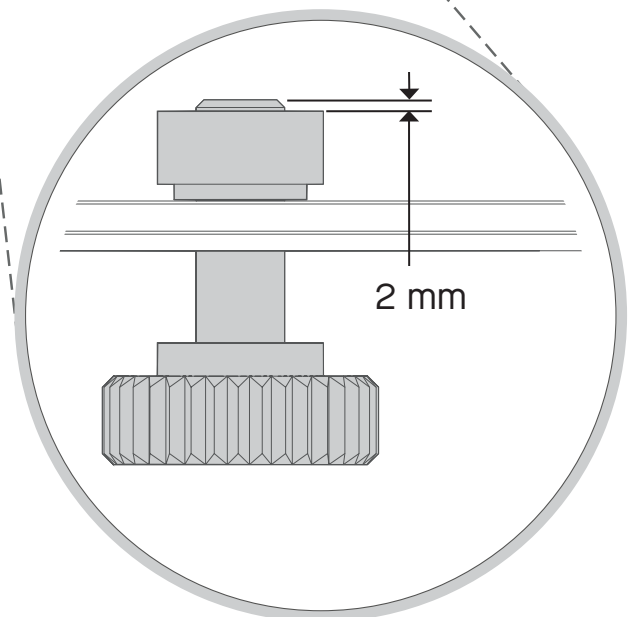
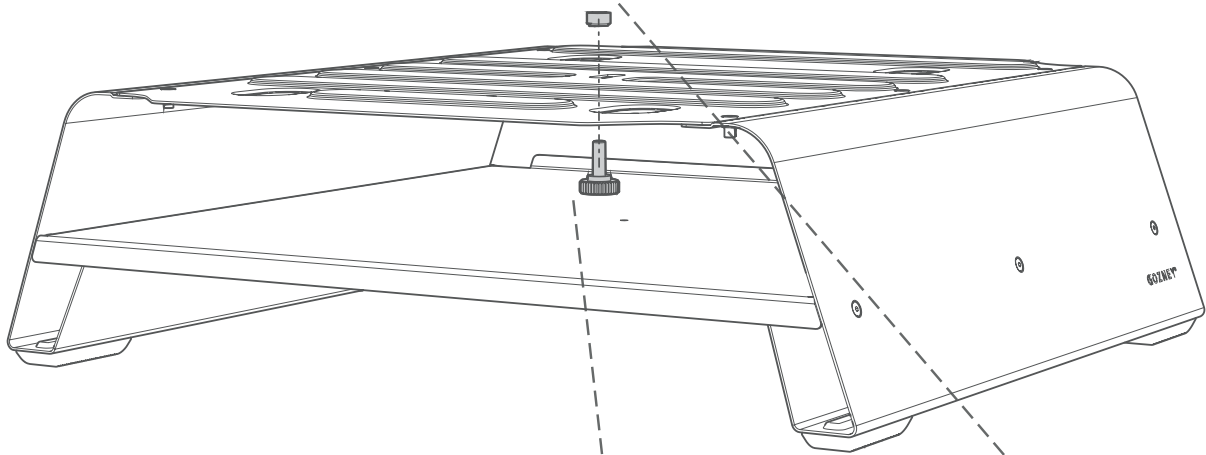
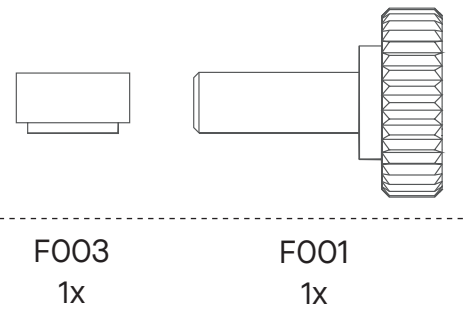

INSTALACIÓN DEL ARC

Antes de instalar el Arc, coloque las fijaciones F00q y F003 en la parte superior del Booster.

No apriete del todo estas dos fijaciones; solo deben sobresalir unos 2 mm de la rosca.

Paso 8

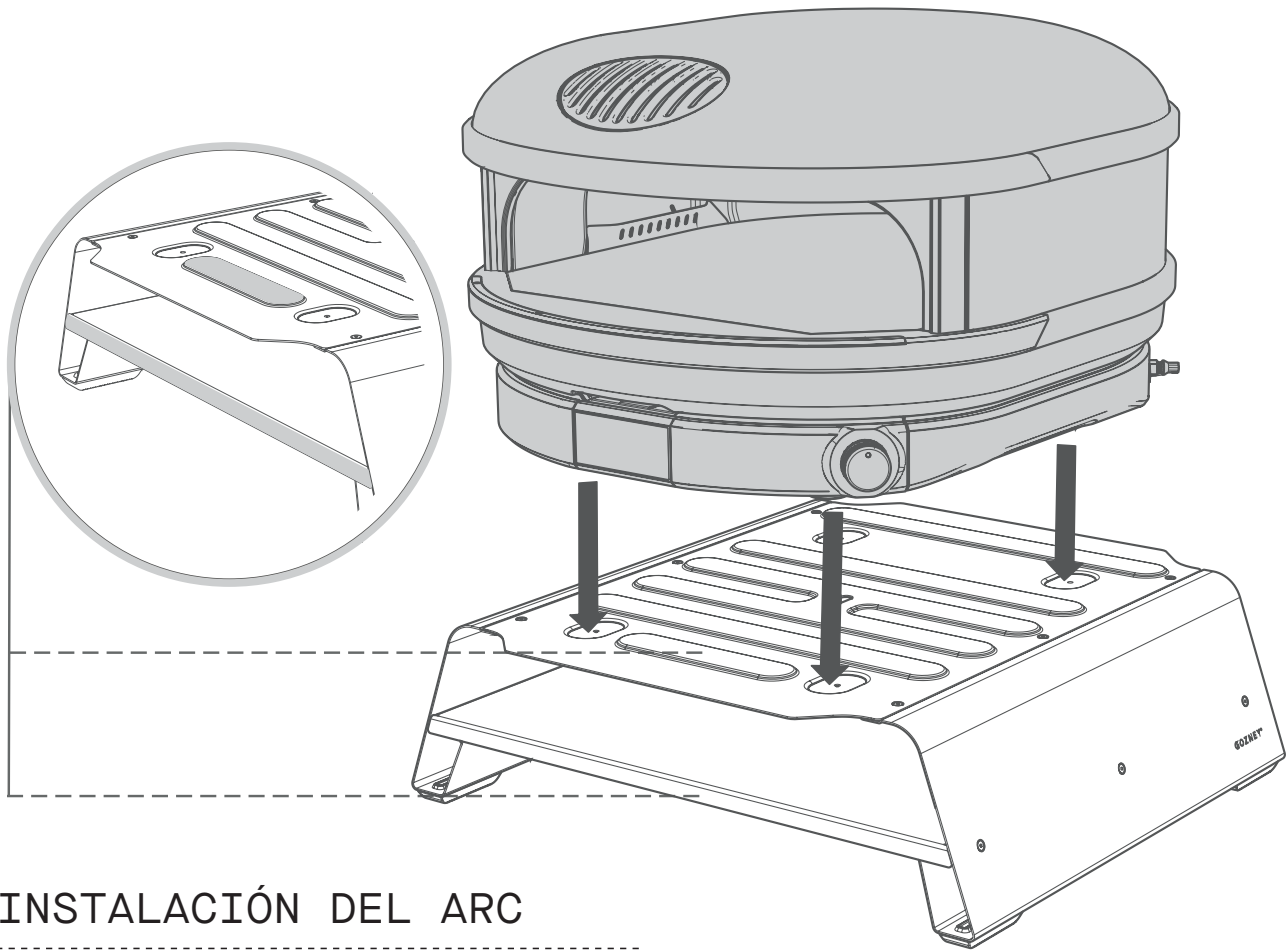

INSTALACIÓN DEL ARC

Asegúrese de que las fijaciones F001 y F003 estén colocadas en el Booster antes de instalar el horno.

—

Retire cualquier objeto suelto del horno antes de moverlo.

—

Para levantar el Arc es necesaria la fuerza de dos personas, que deberán utilizar los puntos de agarre (consulte el manual del Arc)

—

No levante nunca el Arc solo.

—

No se agarre de la boca del horno para levantarlo.

—

Alinee los pies del Arc con las ranuras resaltadas. Asegúrese de que los pies estén completamente alineados antes de continuar.

—

* Tenga en cuenta que la boca del horno debe estar orientada hacia la parte delantera del Booster.

Paso 9

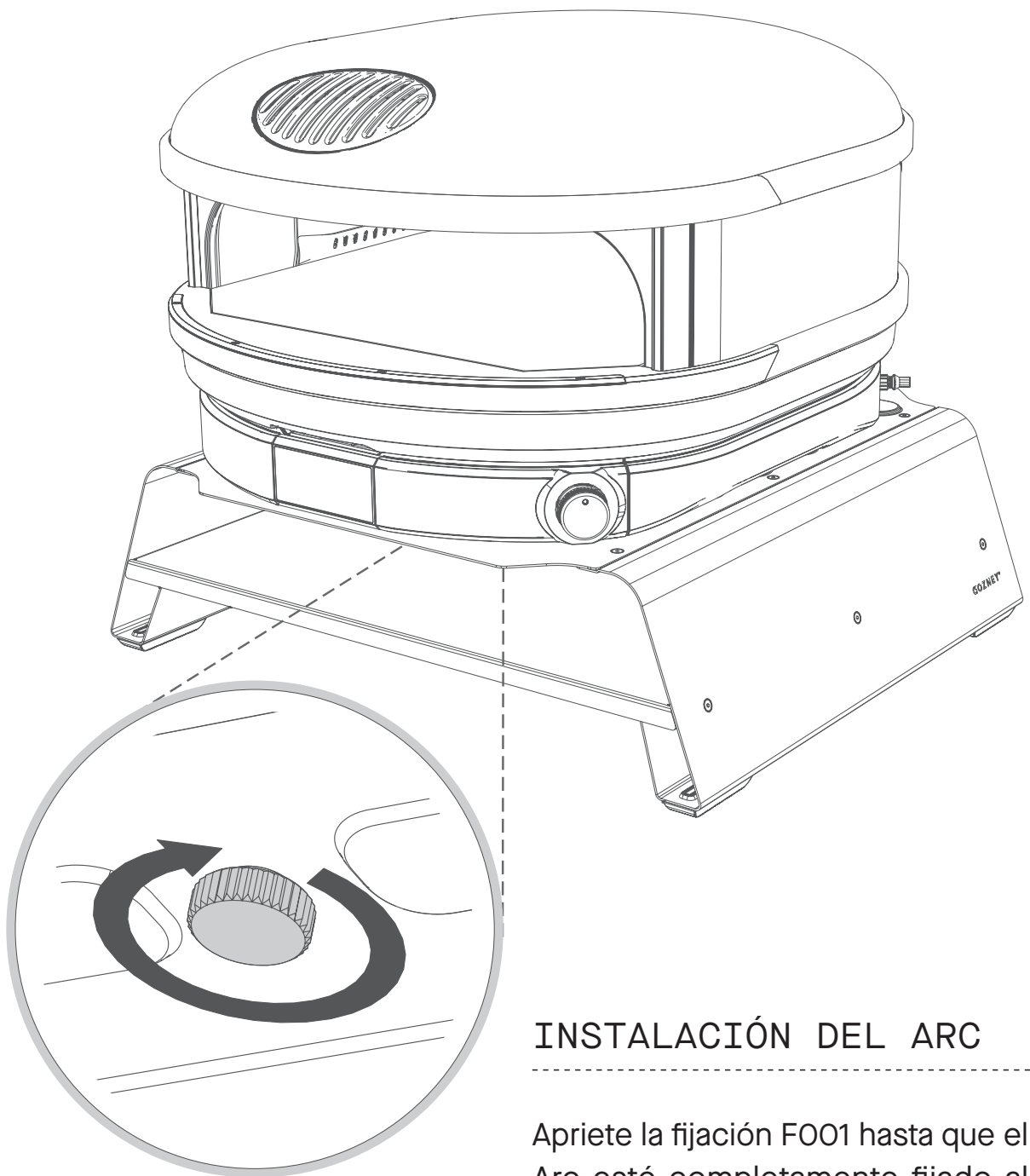

INSTALACIÓN DEL ARC

Apriete la fijación F001 hasta que el Arc esté completamente fijado al Booster.

—
Tenga cuidado de no apretarla demasiado, ya que podría dañar el Booster.

—
No utilice nunca el Arc sin haberlo asegurado al Booster con F001.

Cette section fournit les renseignements essentiels de sécurité liés à l'utilisation du Booster et du four Arc.



Mises en garde et avertissements

Mises en garde et avertissements

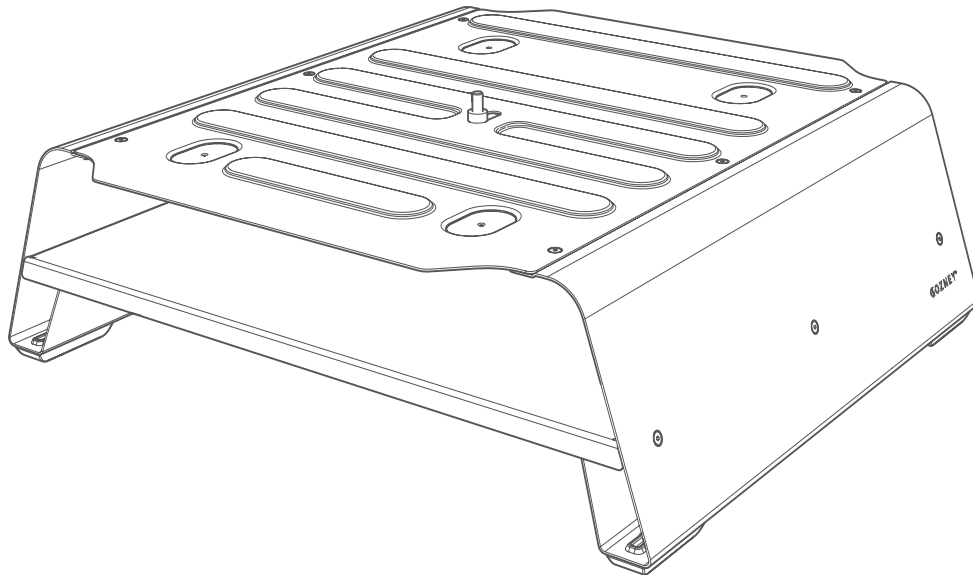

Assurez-vous d'avoir entièrement lu, compris et respecté les avertissements et mises en garde contenus dans le Manuel d'utilisation de l'Arc fourni avec le four.

—

N'essayez jamais de déplacer le four lorsqu'il est encore chaud. Attendez d'abord qu'il refroidisse complètement.

—

Lorsque vous déplacez le four sur le Booster, soulevez toujours en utilisant les points de levage du four, et non le Booster ou la tablette.

—

Enlevez tout ce qui n'est pas fixé du Booster ainsi que ses étagères avant

Le fait de poser des objets chauds provenant du four sur la tablette peut endommager le revêtement. Utilisez les protections appropriées pour éviter tout dommage.

Four à gaz

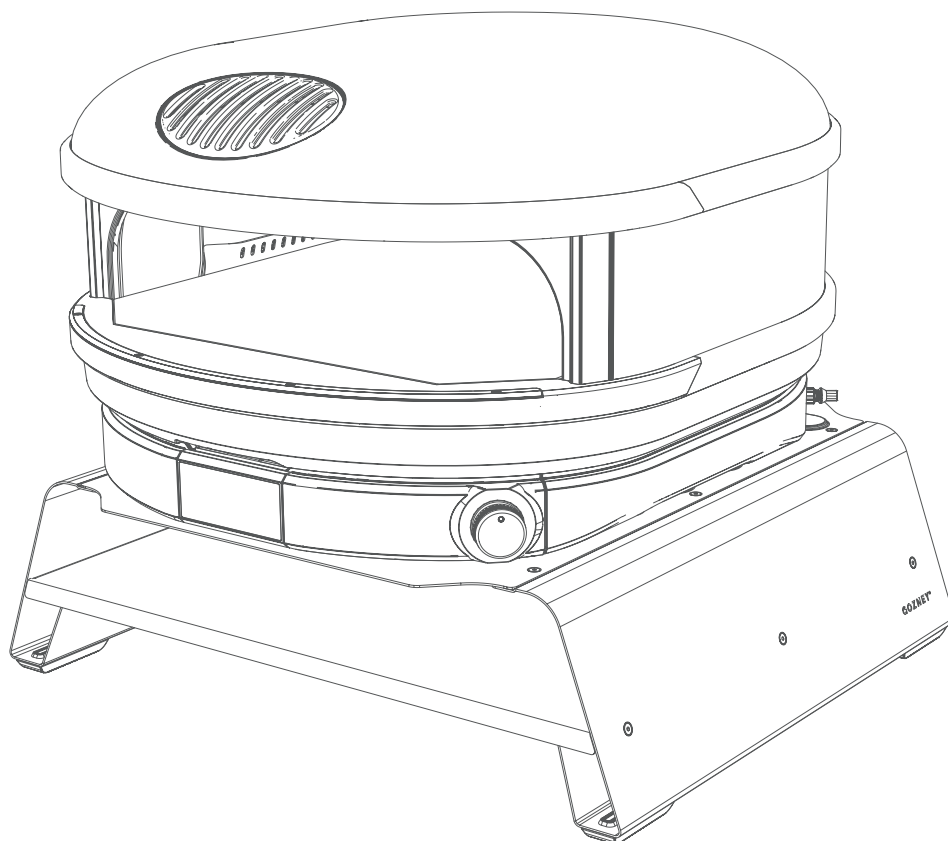

Toujours débrancher le four de l'alimentation de gaz avant de déplacer le four.

Veillez à bien utiliser le raccord gaz Gozney fourni ou un raccord respectant les normes pour appareils à gaz mobiles (ANSI Z21.69 / CSA 6,16) et un dispositif de déconnexion rapide respectant les normes en vigueur (ANSI Z21.41 / CSA 6.9).

Le raccord de gaz et le dispositif de déconnexion rapide ou son tuyau associé ne doivent jamais être utilisés pour limiter le mouvement de l'appareil.

Cette section explique en détail le processus de montage et d'installation du Booster.



Montage et Installation

Manuel de montage

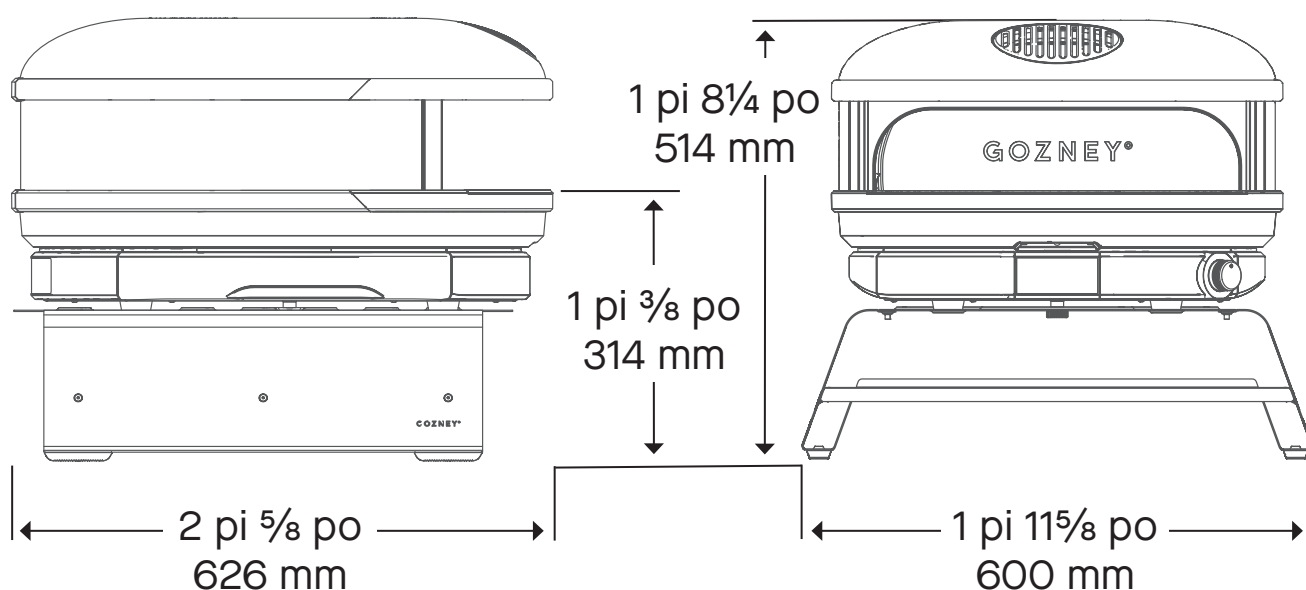

ZONE DE MONTAGE

Procédez au montage du Booster à l'endroit où vous avez l'intention de positionner l'Arc.

Assurez-vous que la surface est bien stable, de niveau et capable de supporter le poids du four.

Ne placez aucune des pièces sur la surface abrasive et évitez d'endommager la peinture des pièces métalliques.

Contenu du carton

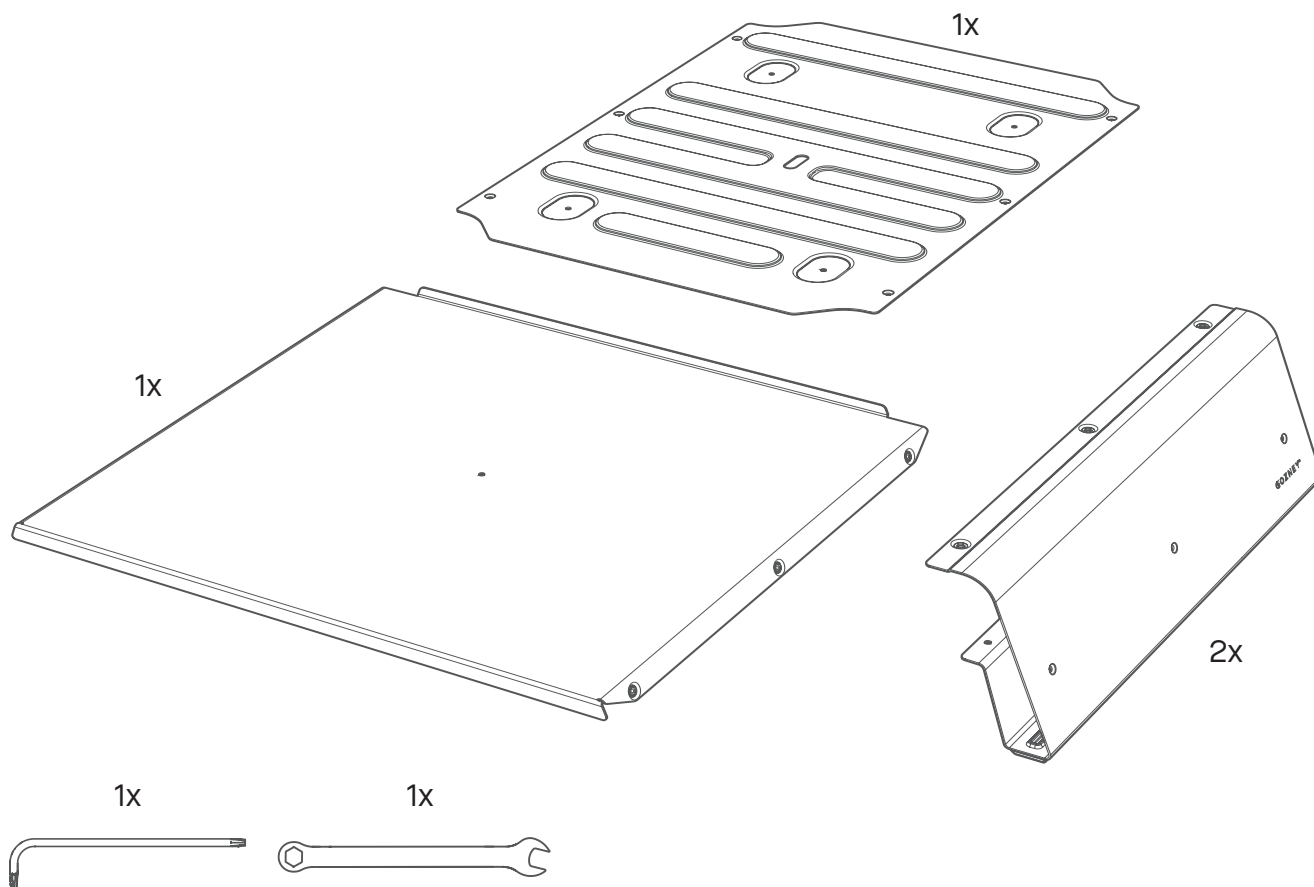

ÉCHELLE 1:1

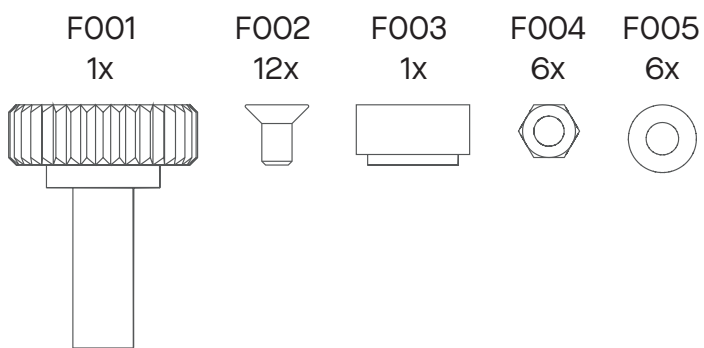

Étape 1

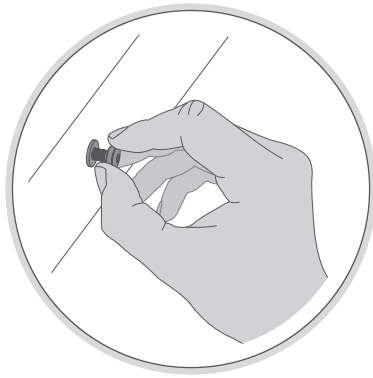

FIXATIONS

Nous recommandons de ne pas visser complètement les écrous et les boulons tant que le Booster n'a pas été assemblé.

—
Cela facilitera le réglage des fixations ultérieures. Vissez complètement à l'Étape 6.



F002
3x

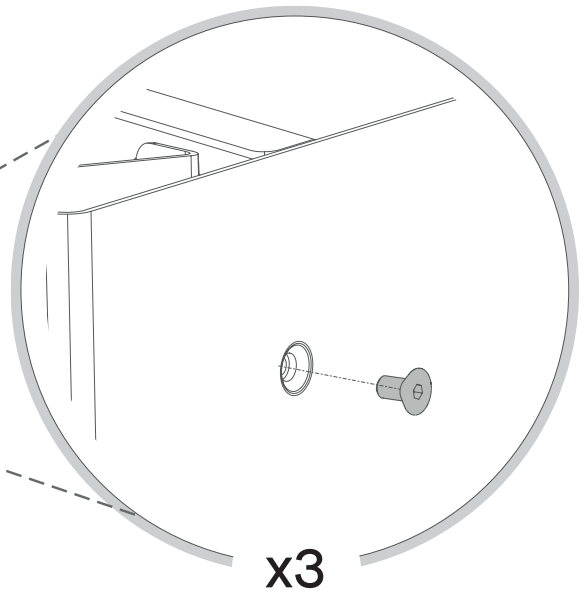
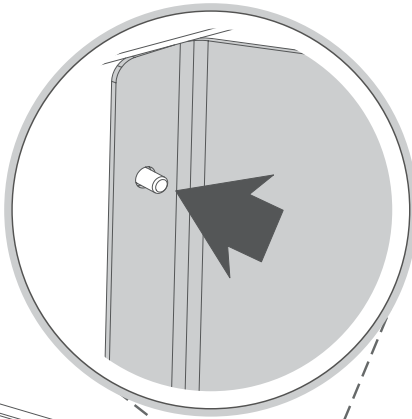

x3

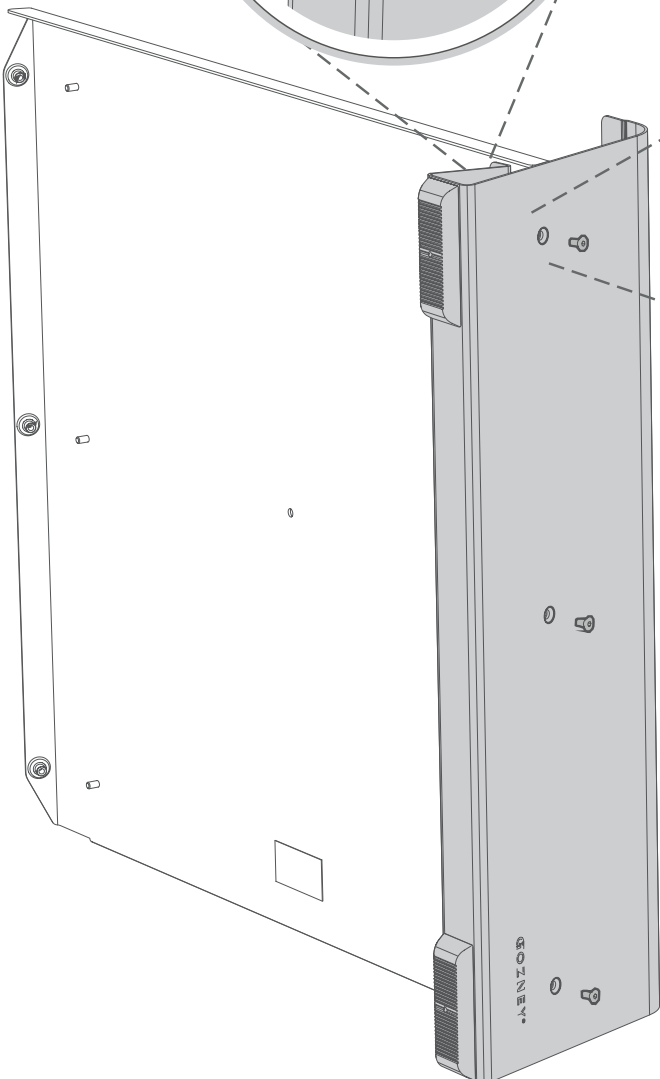

Étape 2



F005
3x

F004
3x

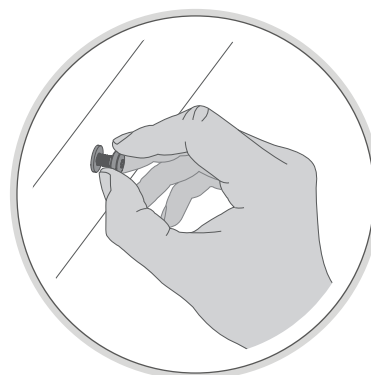
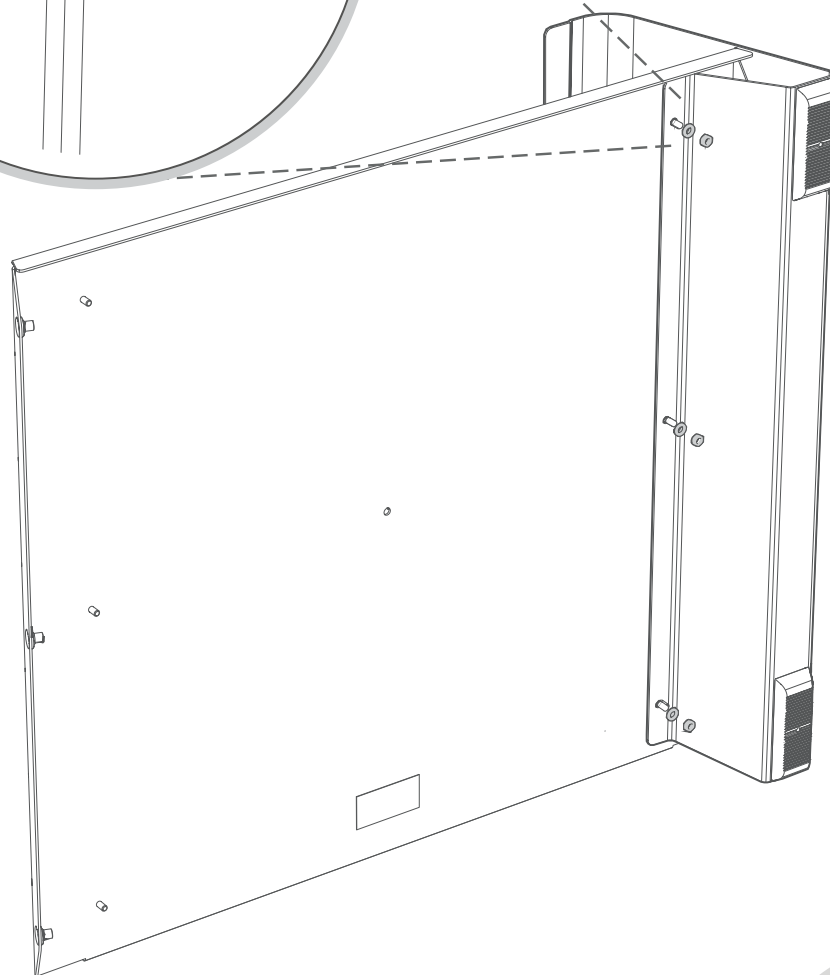
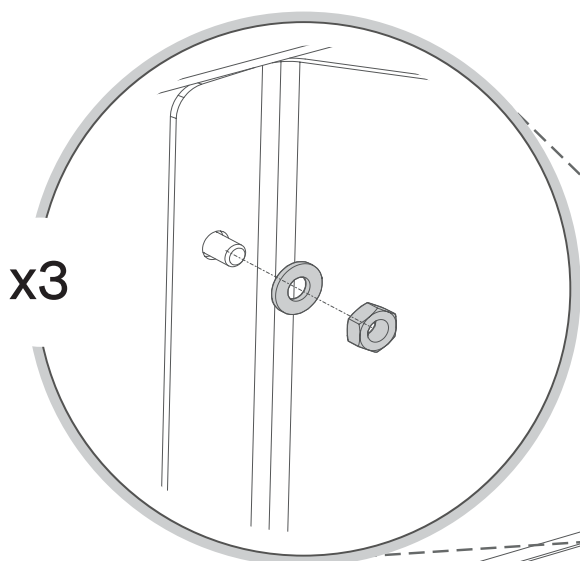

Étape 3



F002
3x

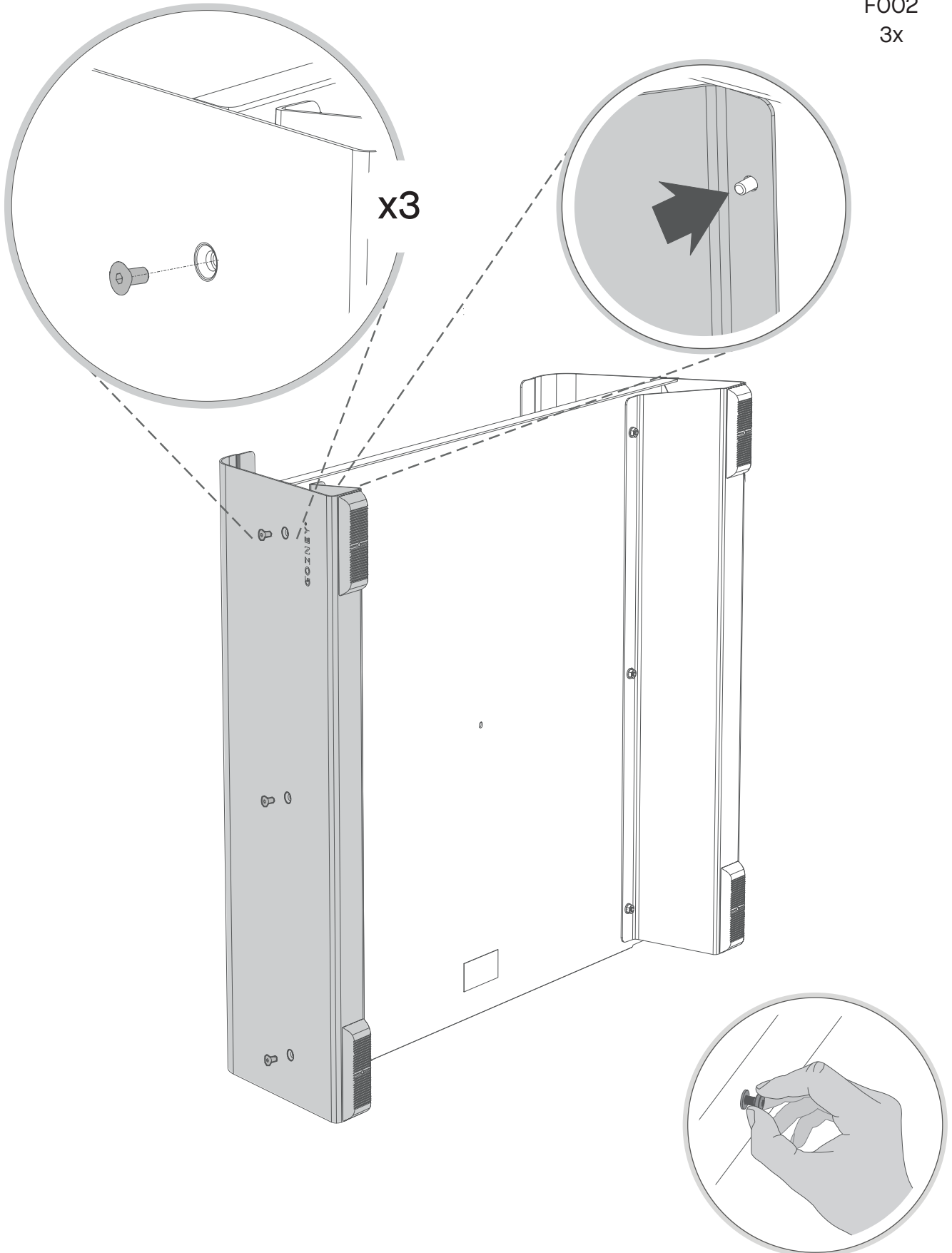

Étape 4



F005
3x

F004
3x

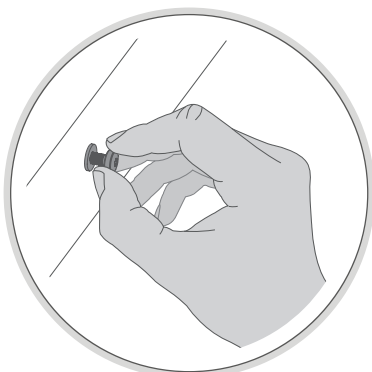
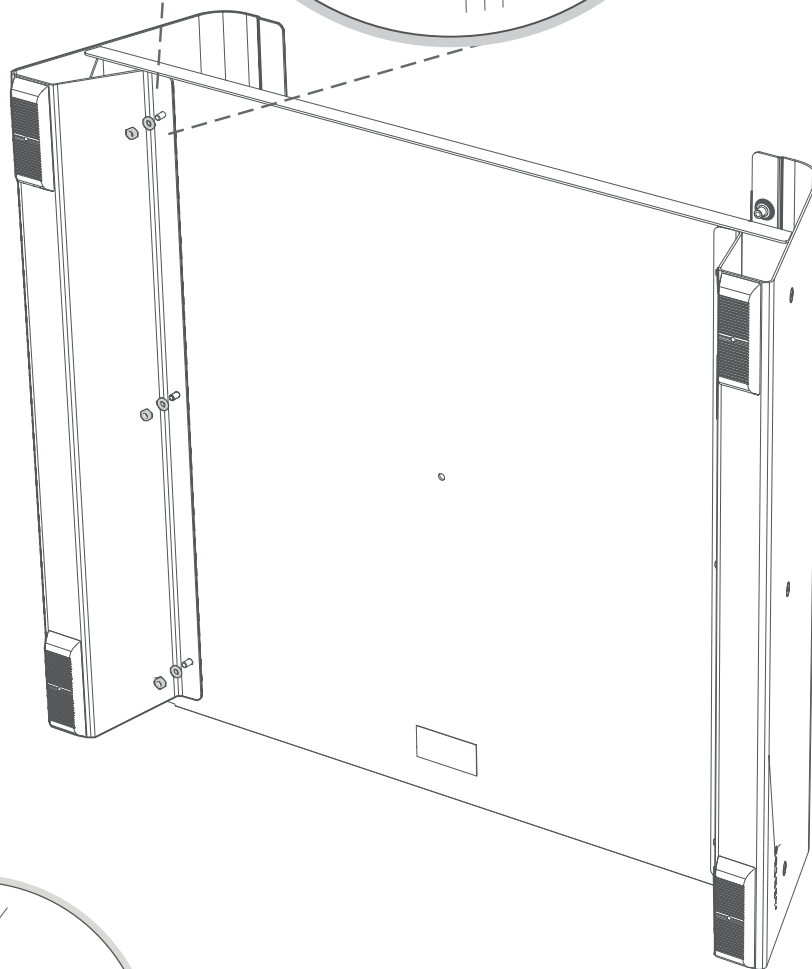

Étape 5



F002
6x

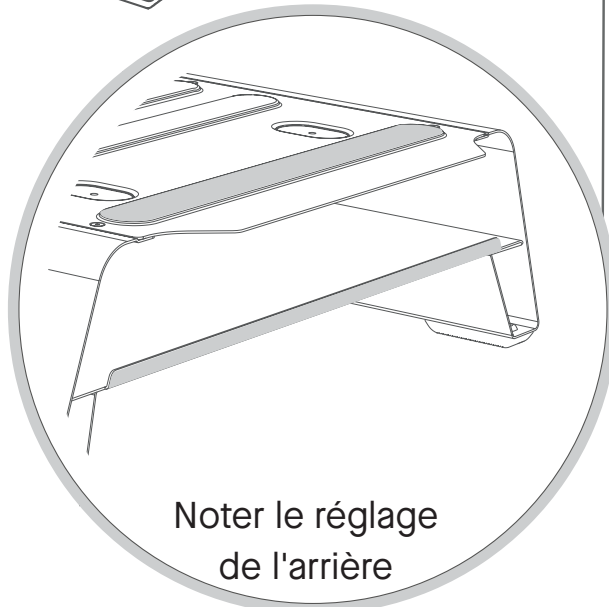
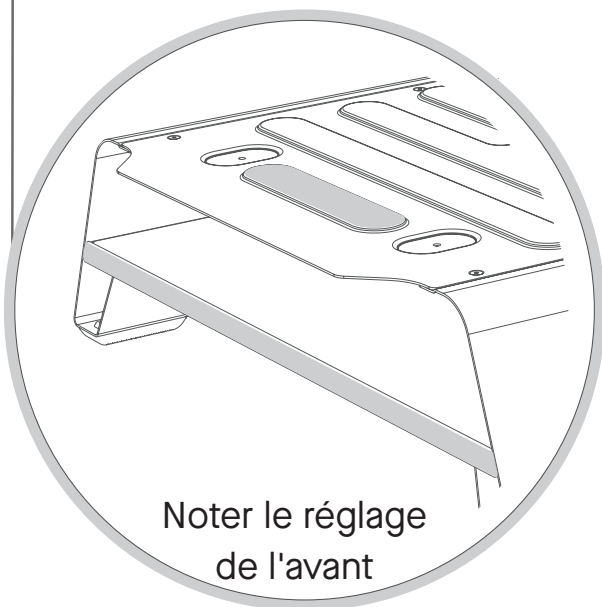
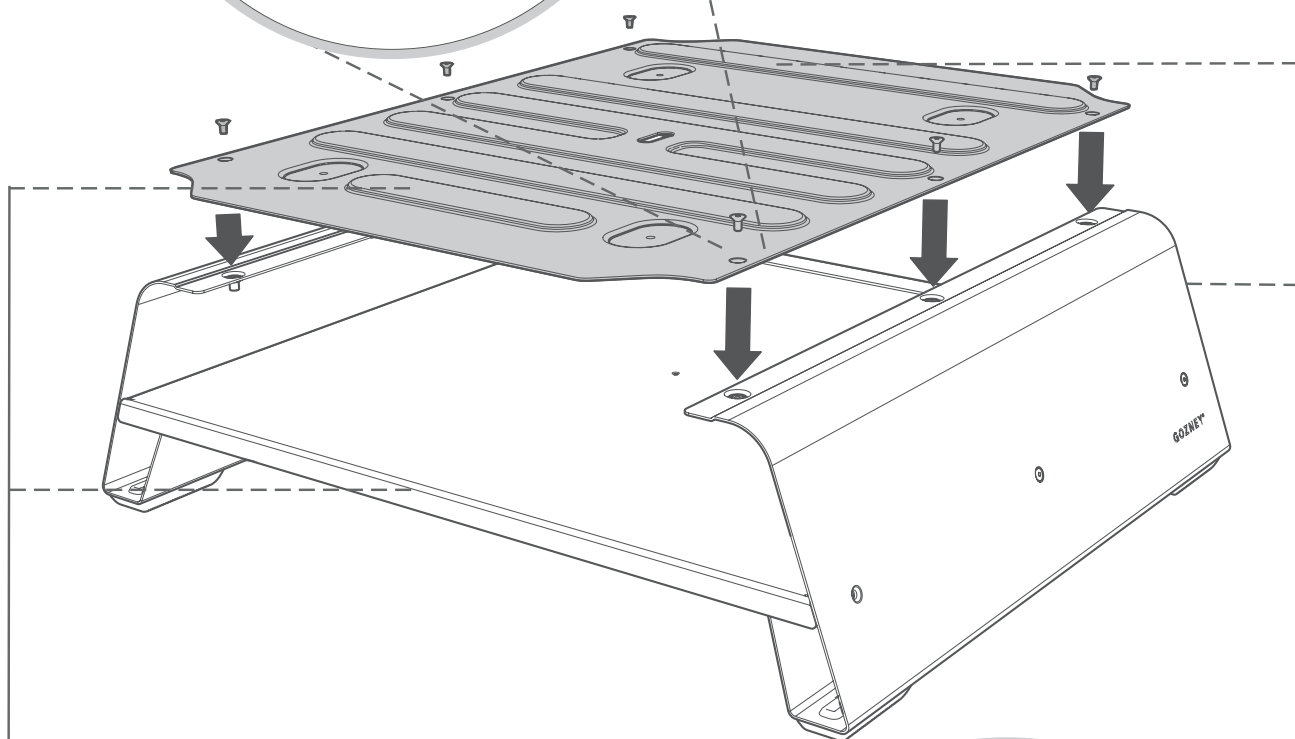
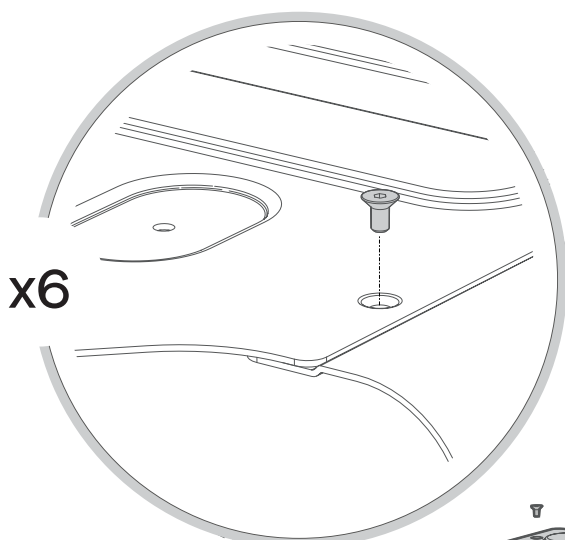

Étape 6

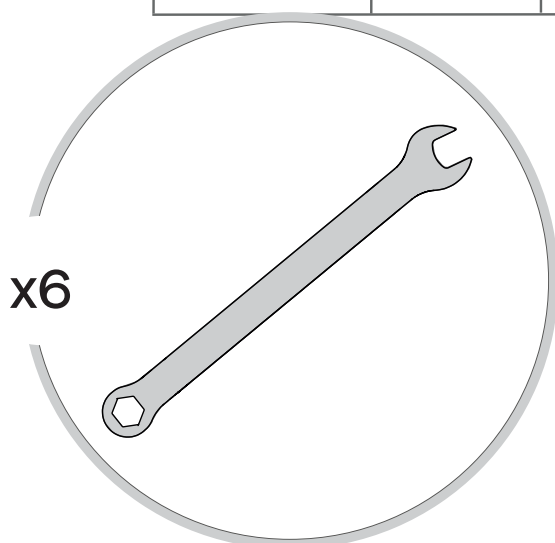
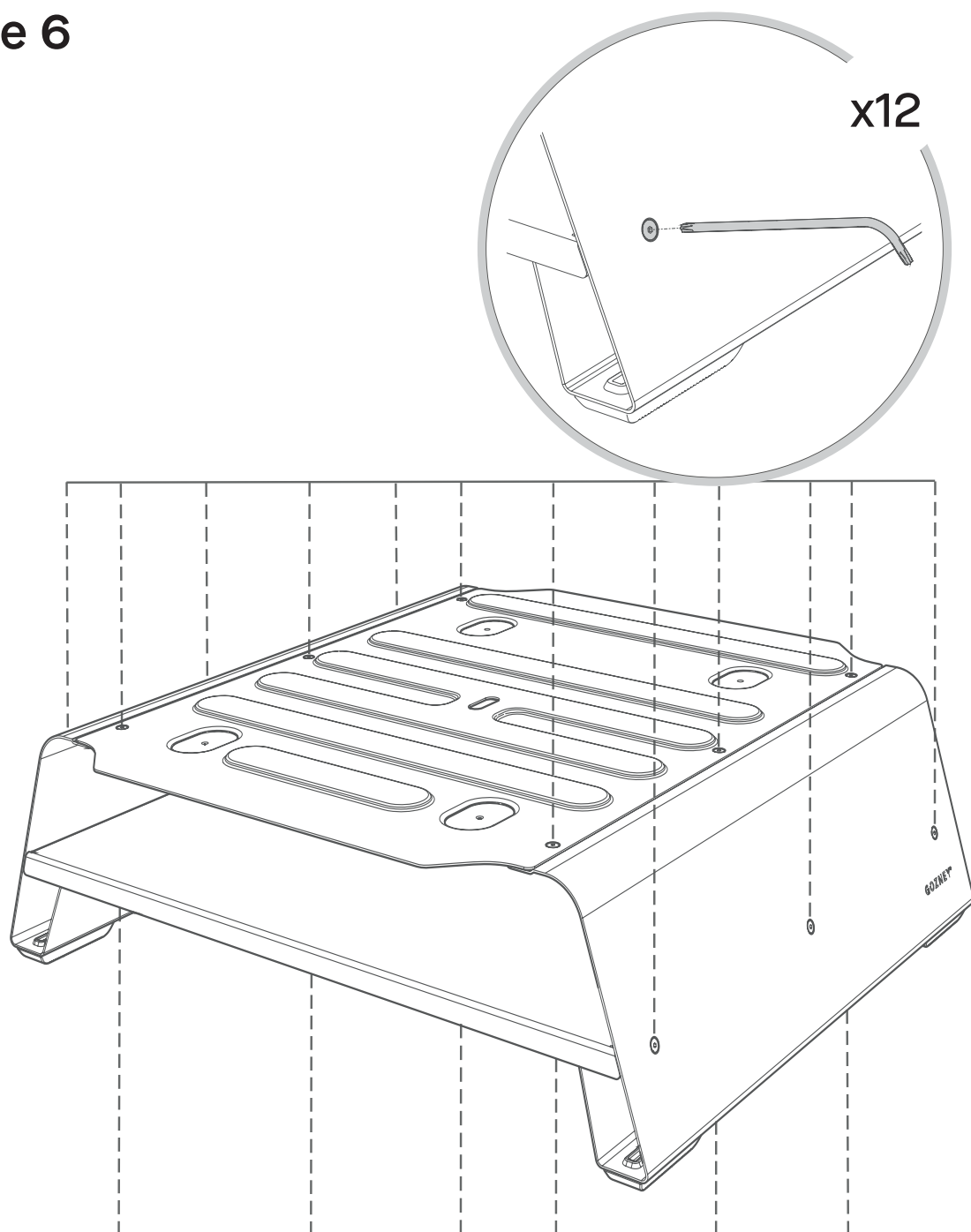

FIXATIONS

Serrez toutes les fixations sur le Booster en veillant à ne pas trop serrer.

Étape 7

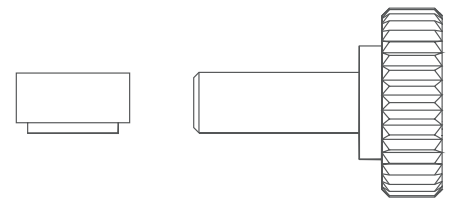

F003
1x

F001
1x

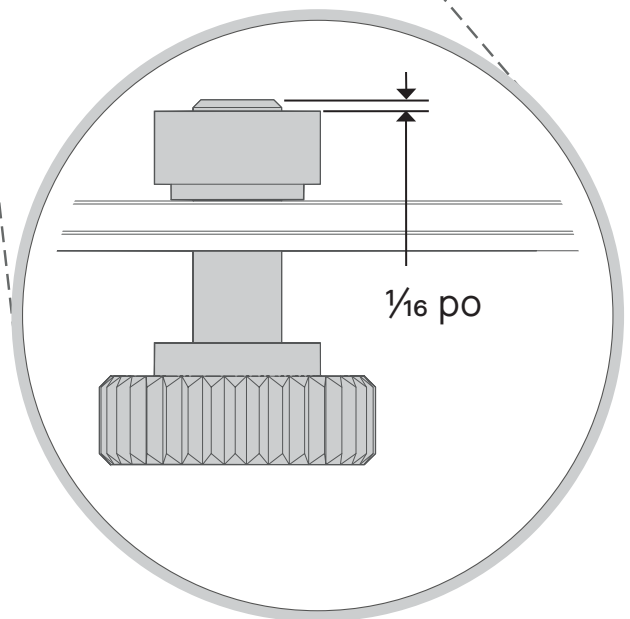
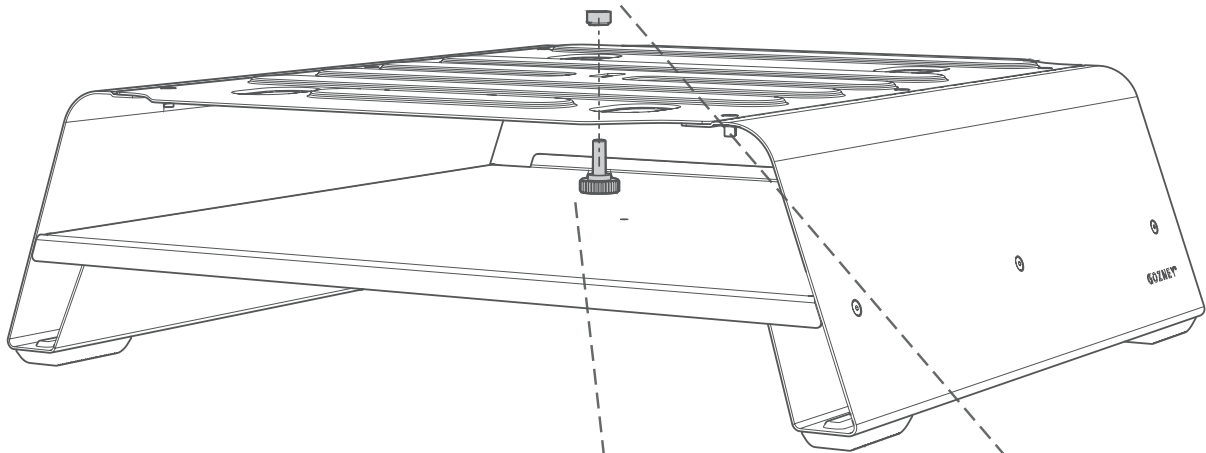

INSTALLER L'ARC

Avant d'installer l'Arc, montez les fixations F006 et F003 sur la partie supérieure de Booster.

Ne vissez pas complètement ces deux fixations, il ne doit pas y avoir plus de 2 mm de filetage exposé.

Étape 8

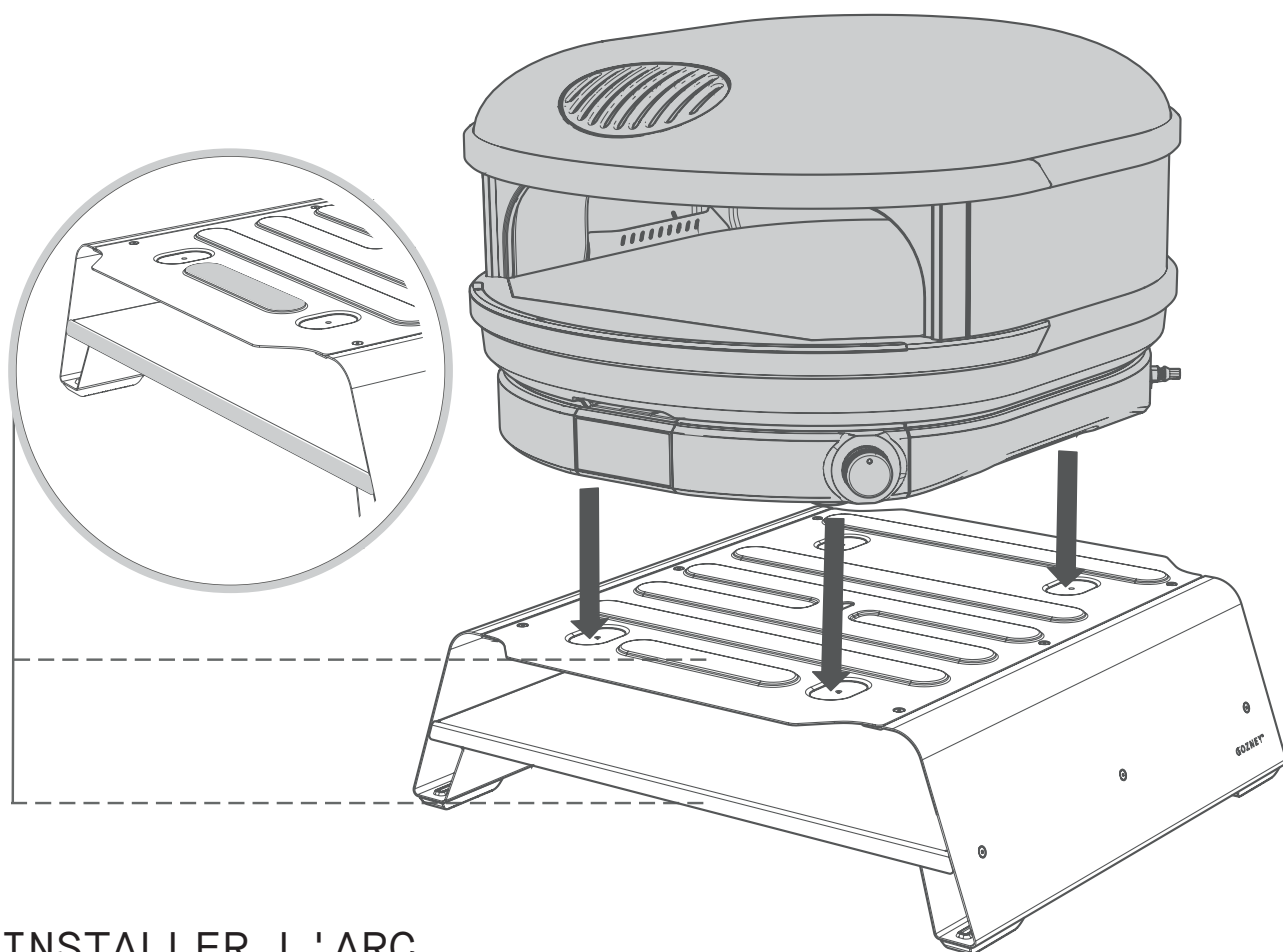

INSTALLER L'ARC

Vérifiez que les fixations F001 et F003 sont bien montées sur le Booster avant d'installer le four.

—

Retirez tout ce qui n'est pas fixé du four avant de le déplacer.

—

Il faut deux personnes pour soulever l'Arc à partir des points de levage (voir le manuel de l'Arc).

—

Ne jamais soulever l'Arc par soi-même.

—

Ne pas utiliser la bouche du four comme point de levage.

—

Ajustez les pieds de l'Arc dans les emplacements mis en évidence. Vérifiez que les pieds sont complètement alignés avant de le déplacer.

—

*Note : la bouche du four doit être orientée vers l'avant du Booster.

Étape 9

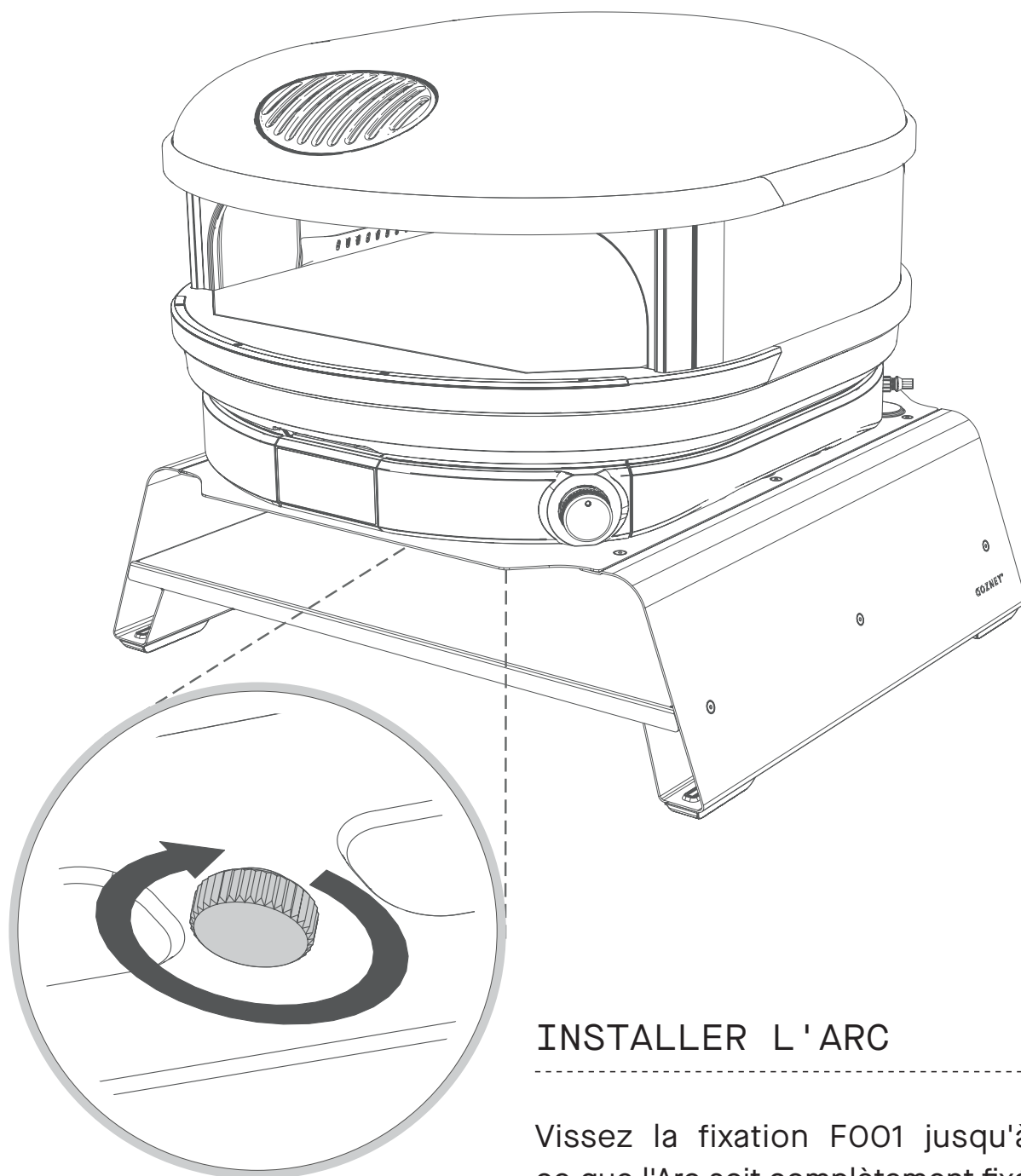

INSTALLER L'ARC

Vissez la fixation F001 jusqu'à ce que l'Arc soit complètement fixé au Booster.

—

Veillez à ne pas trop serrer car cela pourrait endommager le Booster.

—

Ne jamais utiliser l'Arc sans qu'il soit fixé au Booster par F001.

Denne delen beskriver sikkerhetskritisk informasjon knyttet til bruk av booster og Arc-ovnen.



Forsiktingsregler og advarsler

Forsiktighetsregler og advarsler

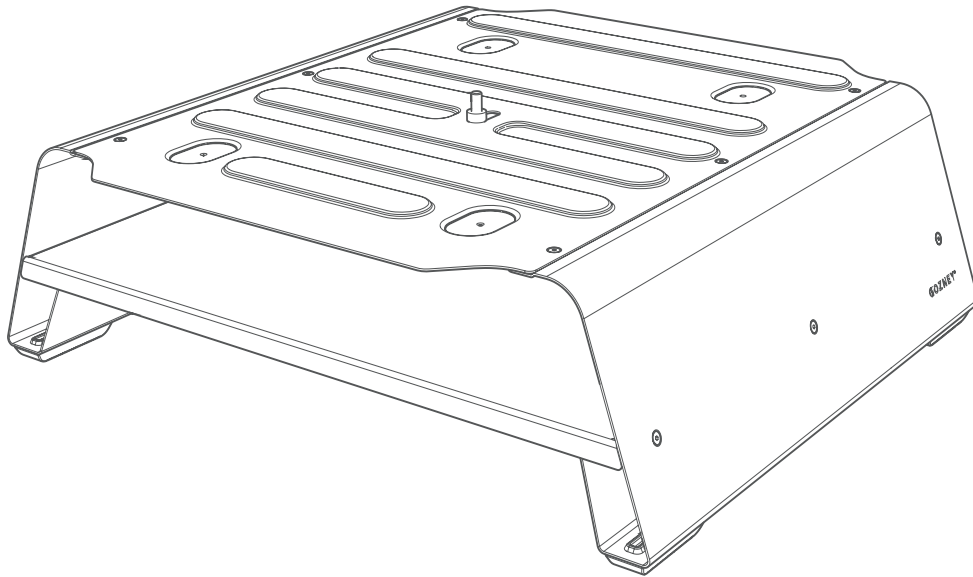

Forsikre deg om at du har lest, forstått og følger forsiktighetsreglene og advarslene i den medfølgende bruksanvisningen for Arc-ovnen.

—

Forsøk aldri å flytte ovnen mens den fortsatt er varm, vent til den er helt avkjølt først.

—

Når du flytter ovnen på boosterens, må du alltid løfte ved å holde i løftepunktene på ovnen og ikke løfte etter boosterens eller hyllens.

—

Fjern alt som er løst fra boosterens og hyllens før du flytter den.

Plassering av varme gjenstander fra ovnen på hyllens kan skade belegget. Bruk passende beskyttelse for å unngå skade.

Gassovn

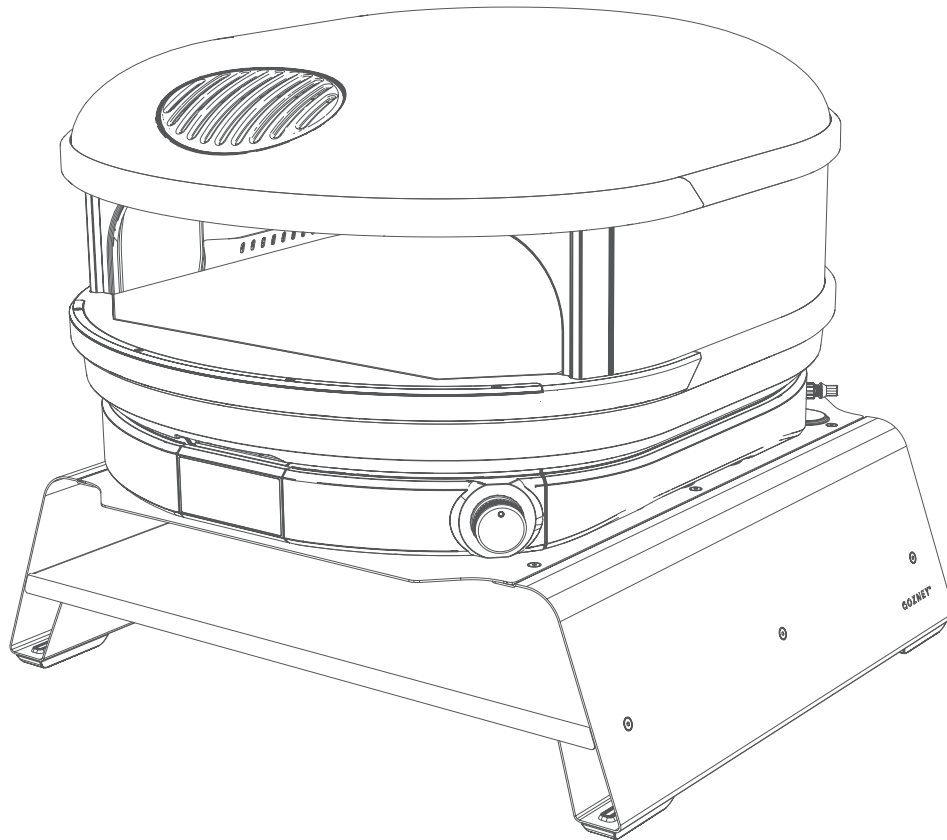

Koble alltid ovnen fra gasstilførselen før du flytter ovnen.

—

Forsikre deg om at du bruker en Gozney-produisert gasskobling eller en kobling som samsvarer med standarden for bevegelige gassapparater (ANSI Z21.69 / CSA 6.16), og en hurtigfrakoblingsenhet som samsvarer med de relevante standardene (ANSI Z21.41 / CSA 6.9).

Gasskoblingen og hurtigfrakoblingsenheten eller tilhørende rør skal aldri brukes til å begrense bevegelsen til apparatet.

Denne delen beskriver prosessen med å sette opp boosterene og installere den.



Oppsett og installasjon

Byggeanvisning

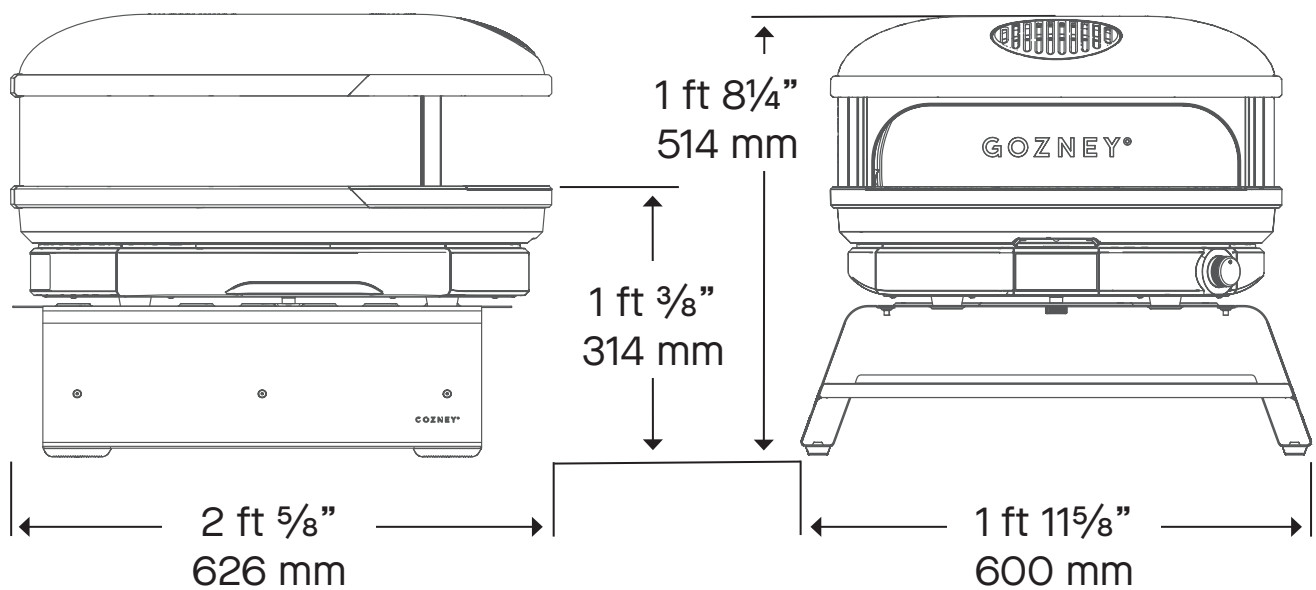

BYGGEOMRÅDE

Bygg boosterens i området du har tenkt å plassere Arc-ovnen.

Sørg for at bakken er stabil og jevn og i stand til å bære ovnens vekt.

Ikke plasser noen av delene på en slipende overflate og unngå å skade lakken på metalledene.

Innholdet i esken

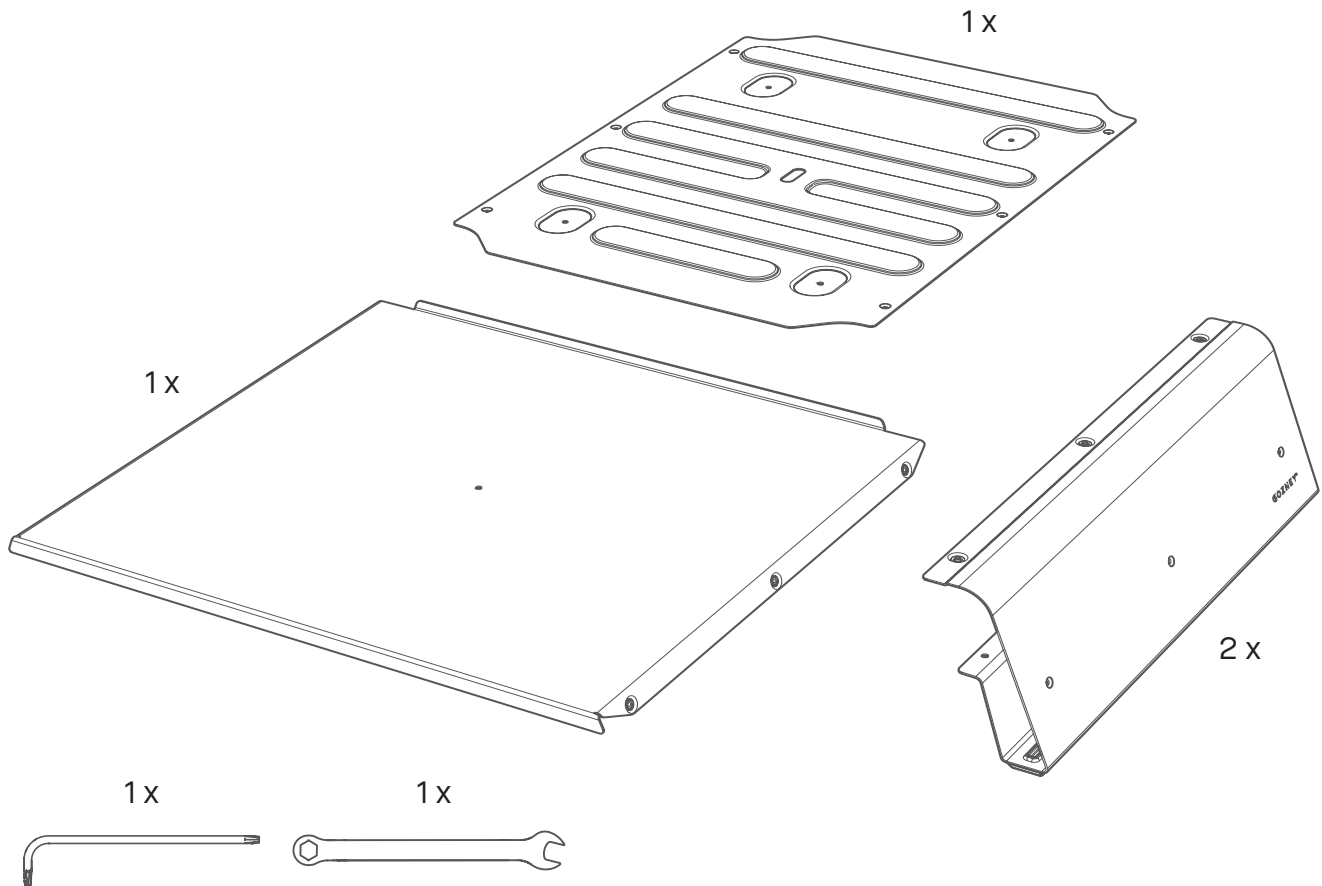

SKALA 1:1

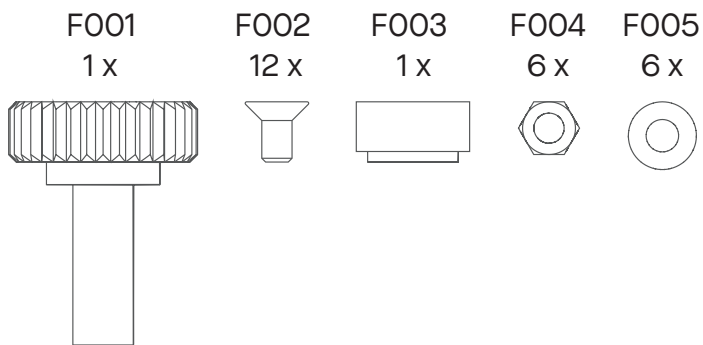

Trinn 1

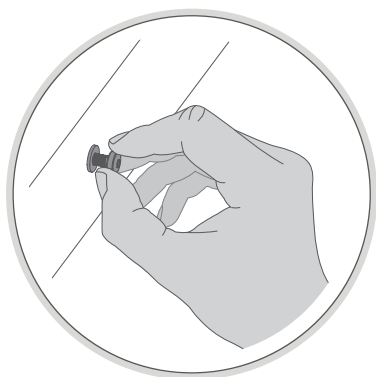

FESTER

Vi anbefaler at du ikke strammer muttere og bolter før boosterens er satt opp.

—
Dette vil gjøre det enklere å justere festene senere. Stram ferdig i trinn 6.



F002
3x

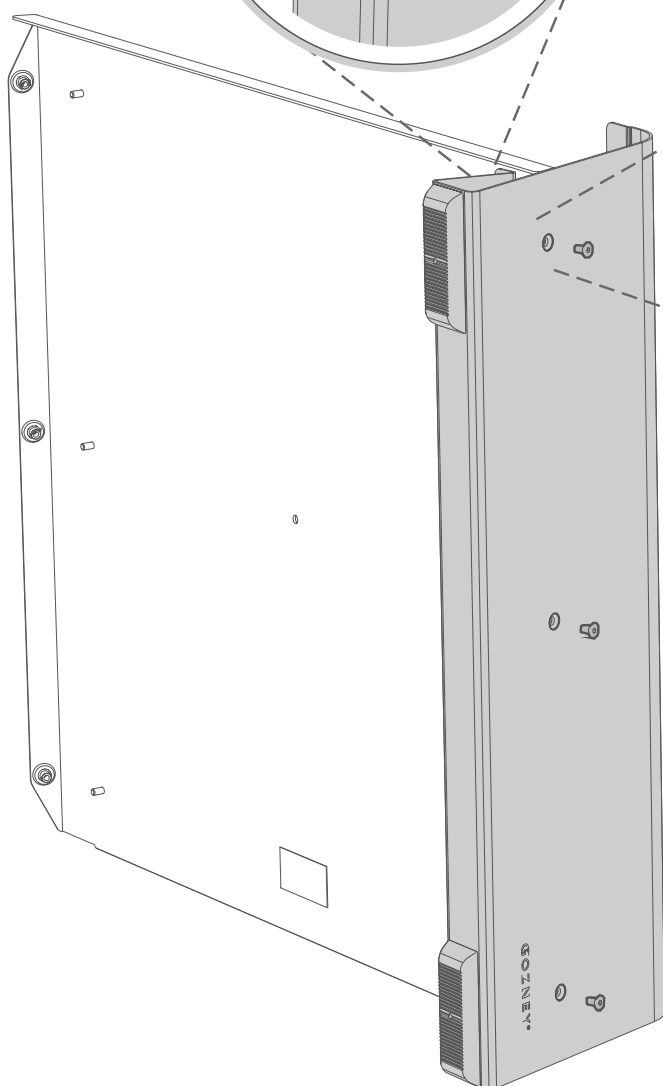
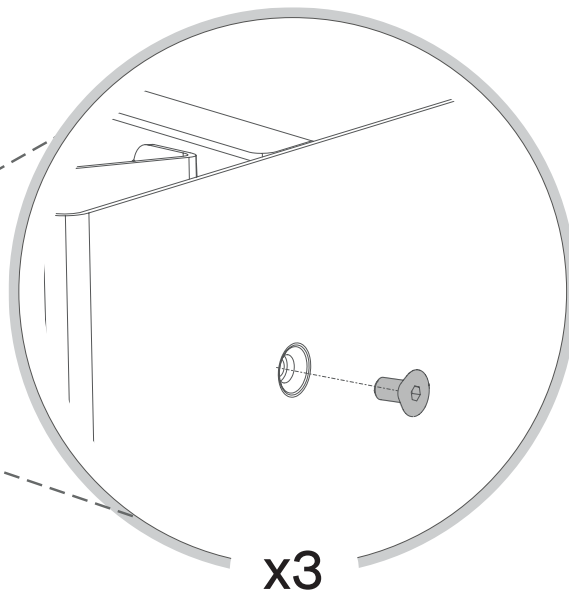
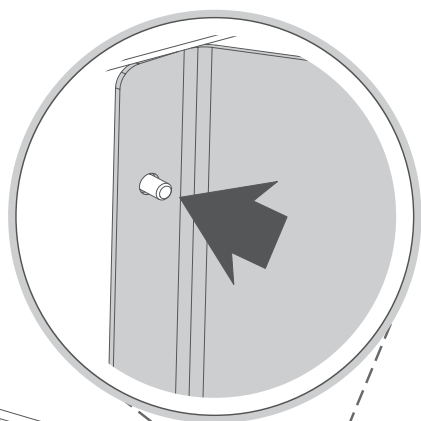

Trinn 2



F005
3x

F004
3x

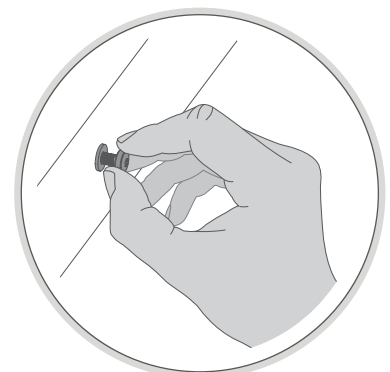
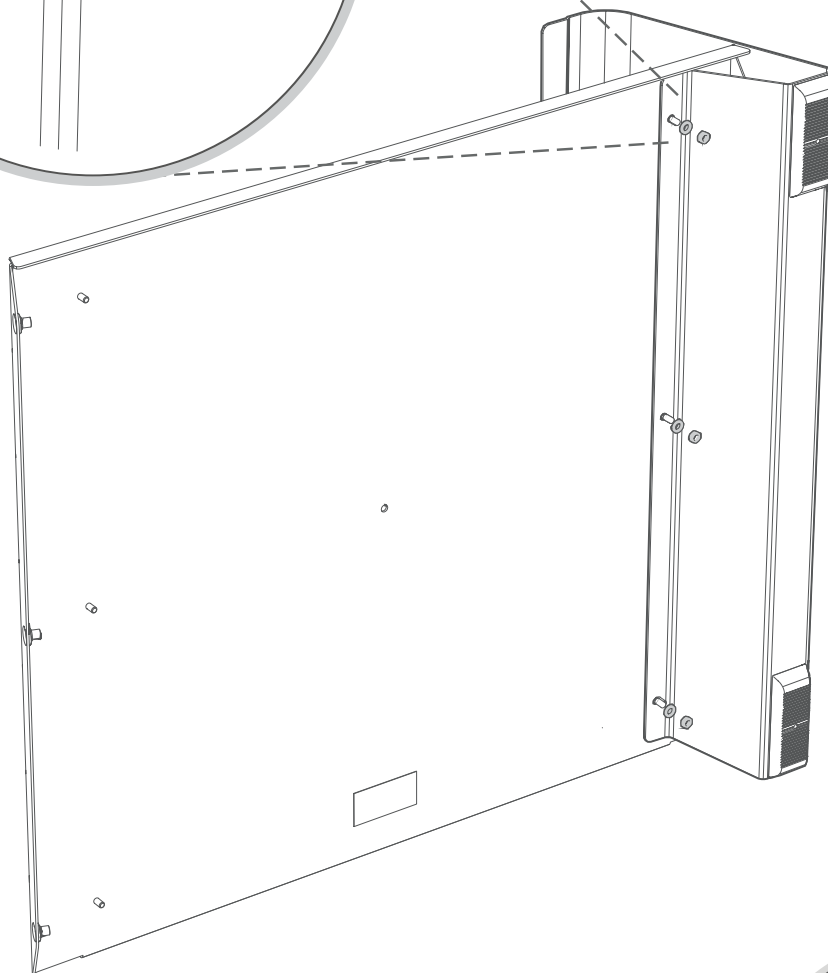
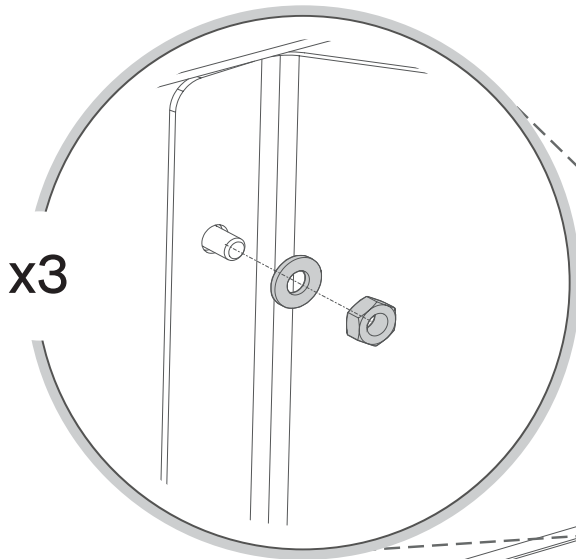

Trinn 3



F002
3x

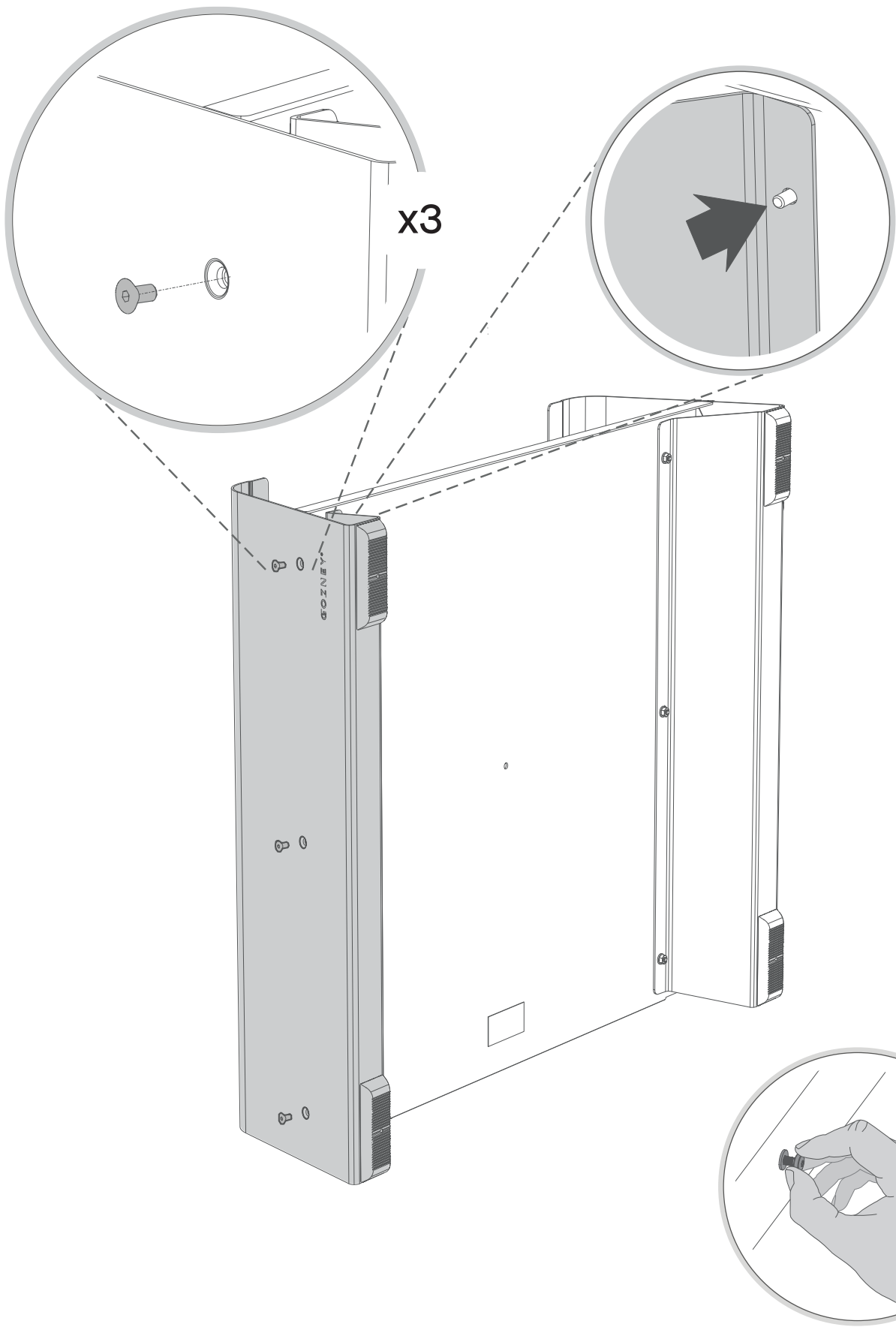

Trinn 4



F005
3x

F004
3x

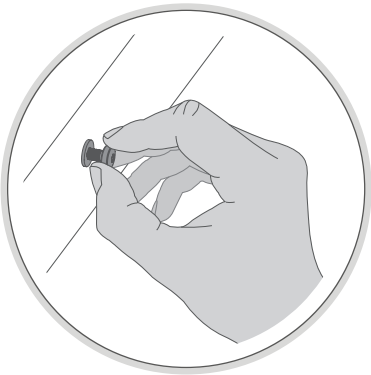
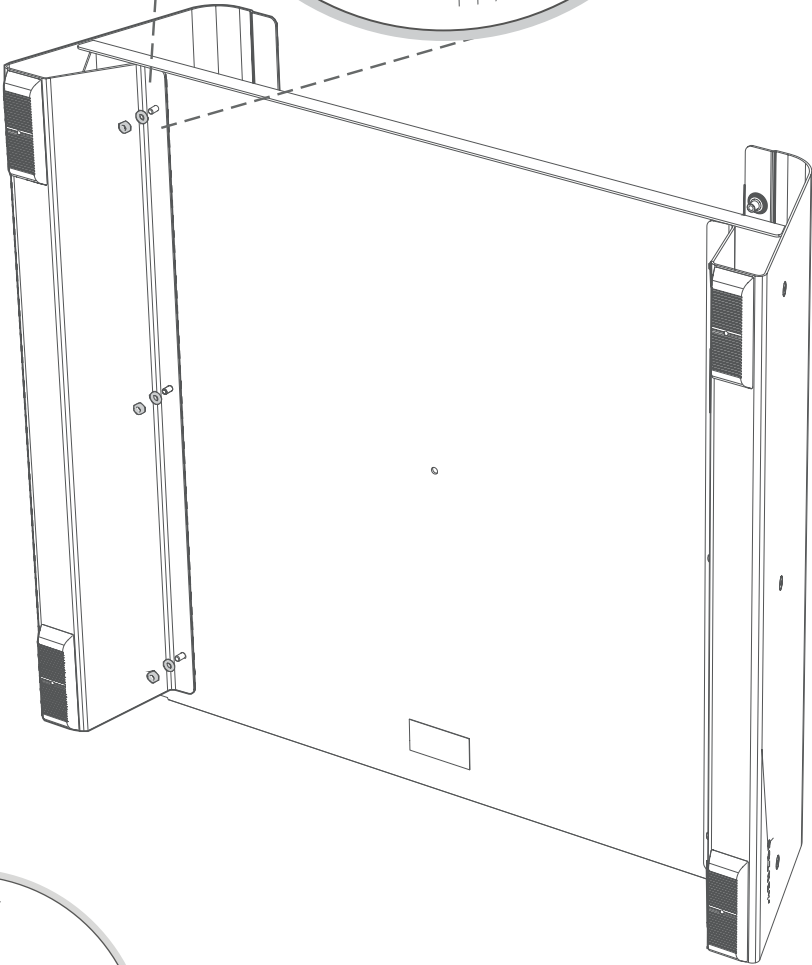
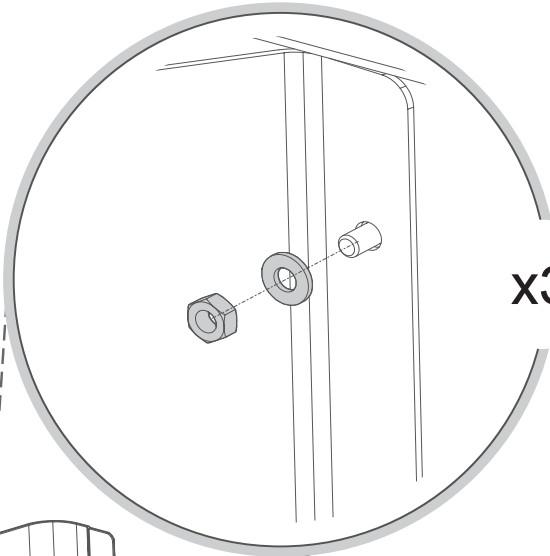

Trinn 5



F002
6 x

x 6

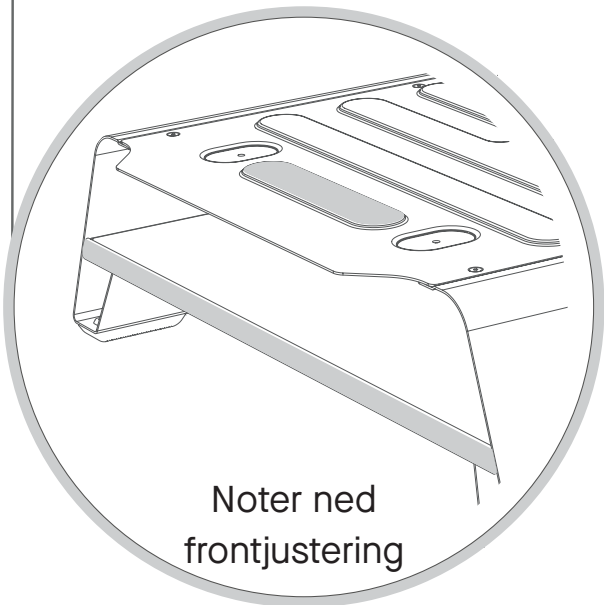
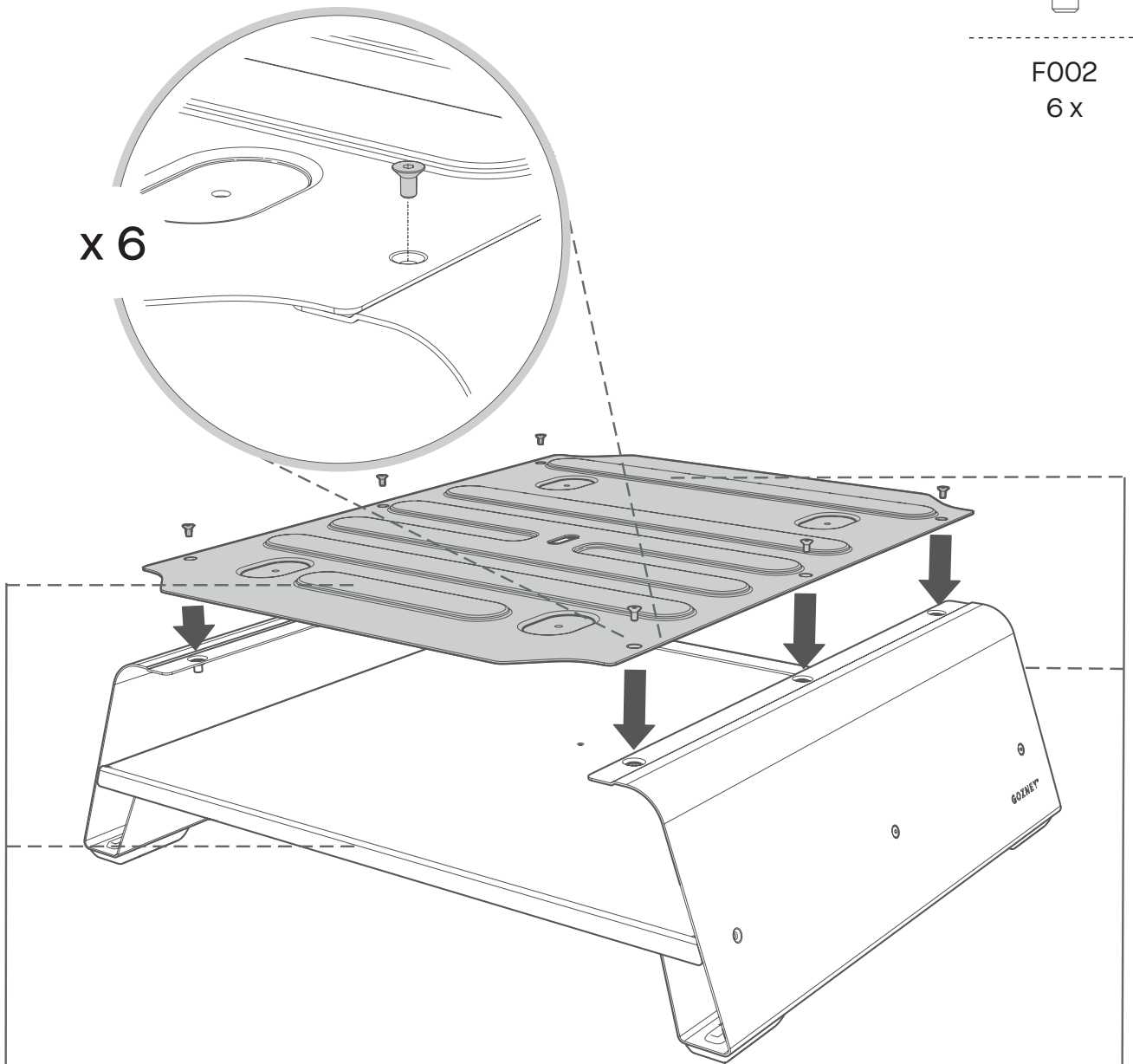

Noter ned
frontjustering



Noter ned bakre
justering

Trinn 6

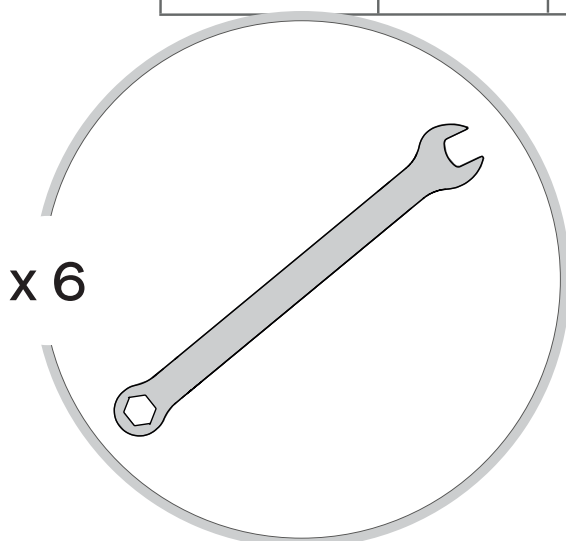
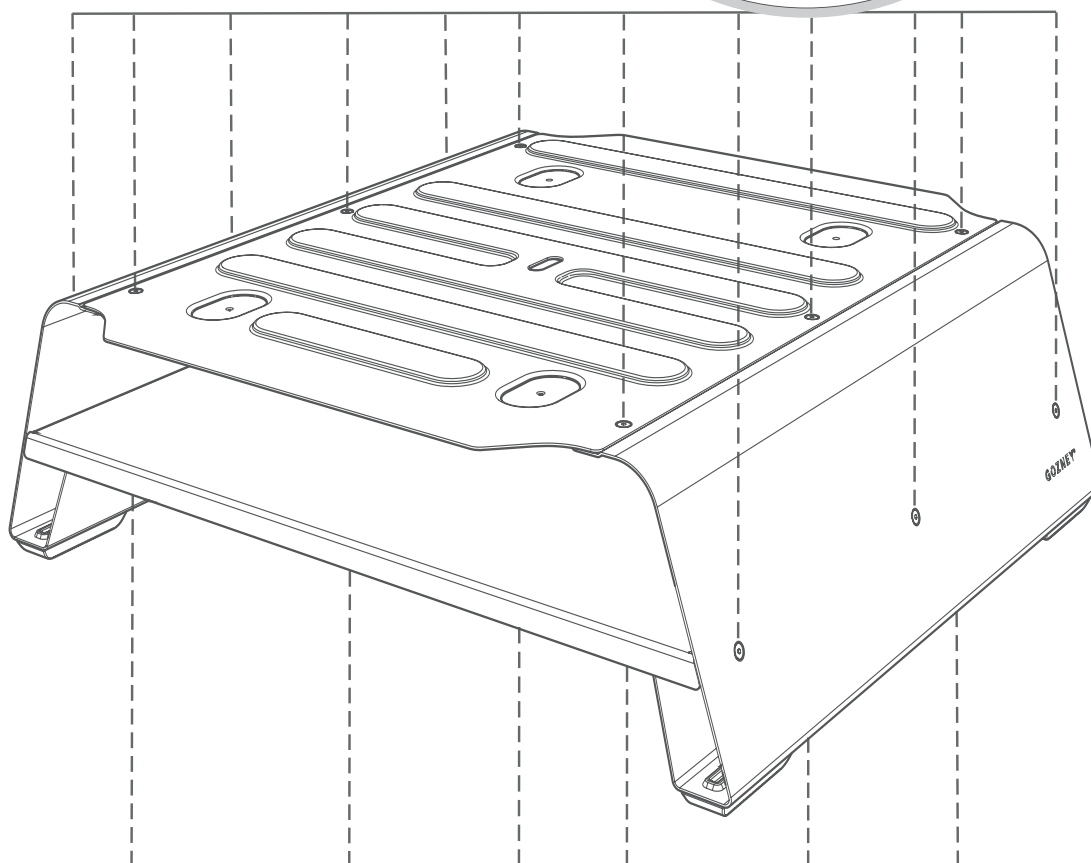
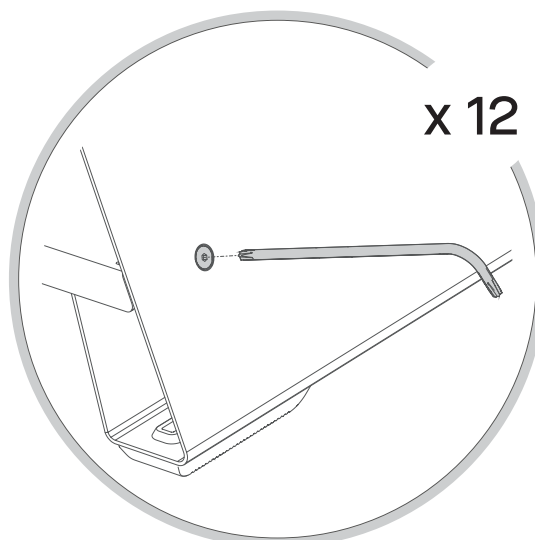

FESTER

Stram til alle fester på boosterens. Pass på at du ikke strammer for mye.

Trinn 7

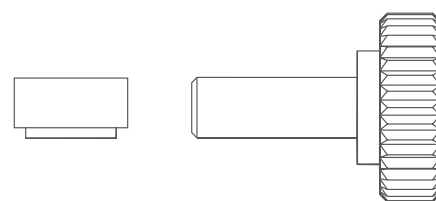

F003

1 x

F001

1 x

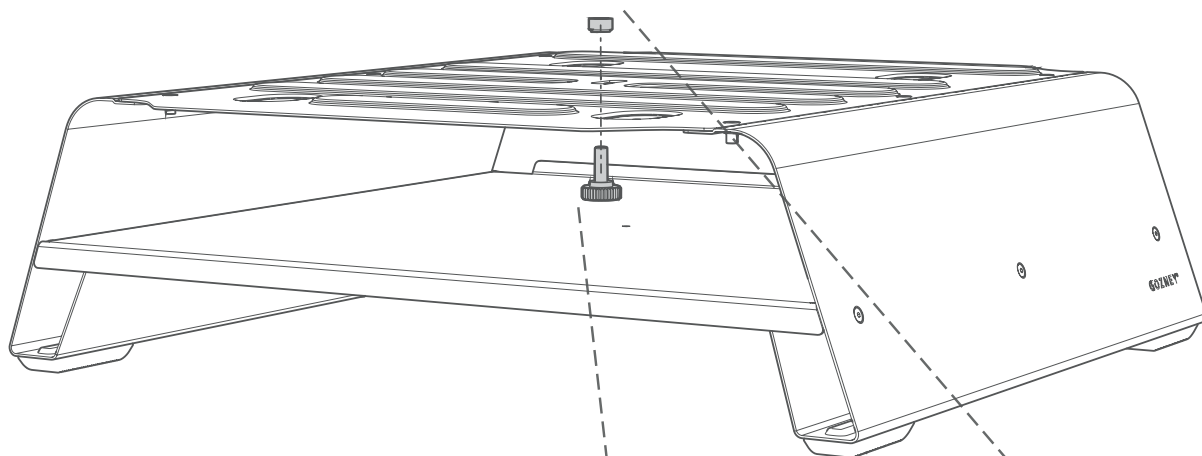

INSTALLERE ARC

Før du installerer Arc-ovnen, må du montere festene F001 og F003 på toppen av boosterens.

Ikke stram disse to festene helt, det skal ikke være mer enn $\frac{1}{16}$ " (2 mm) av gjengene som er synlig

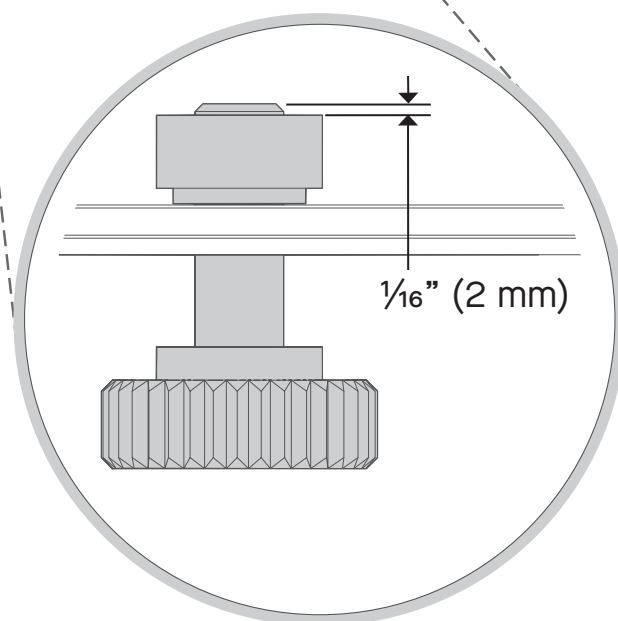

Trinn 8

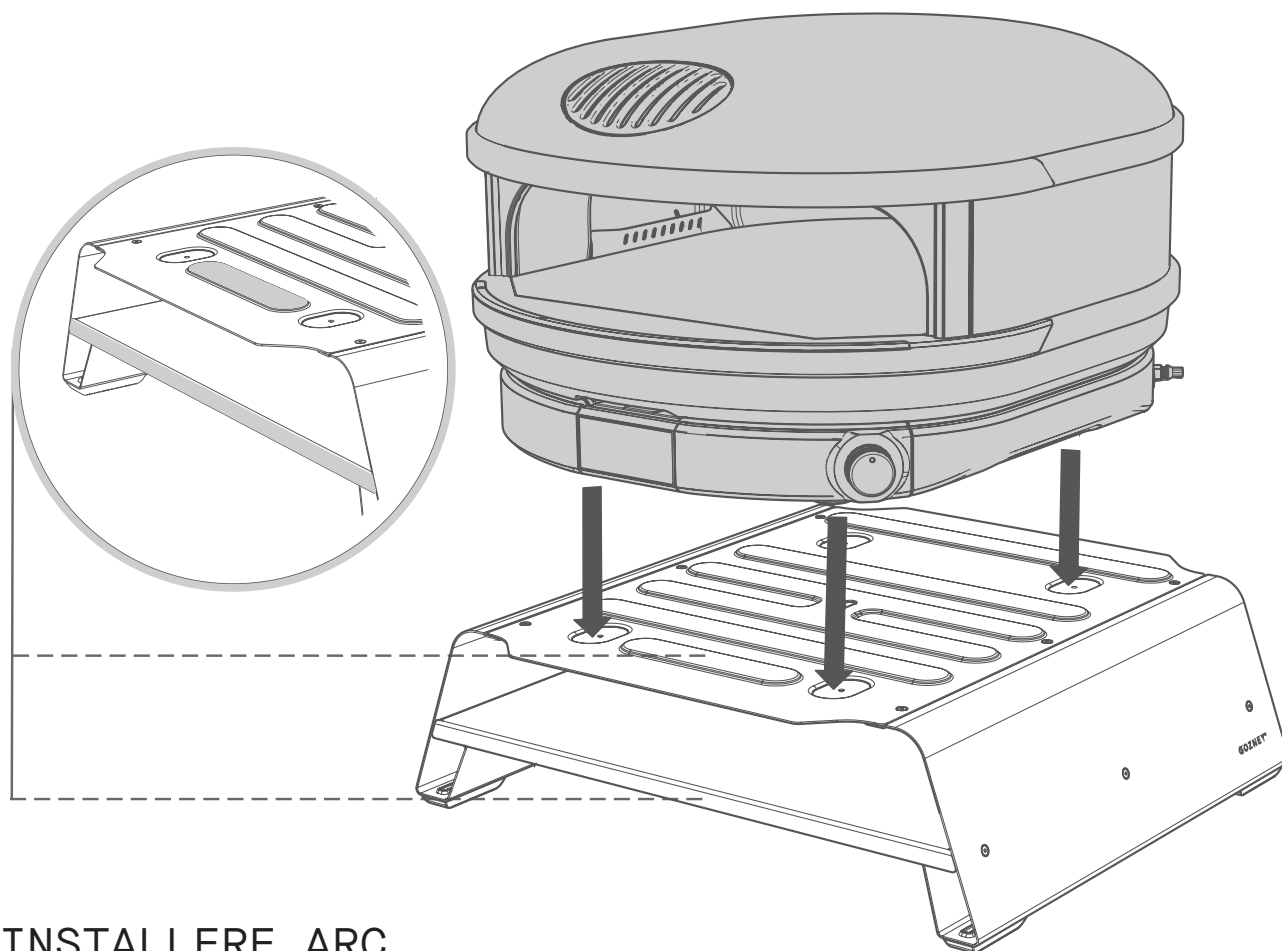

INSTALLERE ARC

Sørg for at festene F001 og F003 er monterte i boosterens før du installerer ovnen.

Fjern alt som er løst på ovnen før du flytter den.

Arc-ovnen bør løftes av to personer ved å holde i løftepunktene til ovnen (se bruksanvisningen for Arc-ovnen).

Løft aldri Arc-ovnen på egen hånd.

Ikke bruk ovnsåpningen som løftepunkt.

Juster føttene til Arc med de uthevede fordypningene. Sørg for at føttene er helt på linje før du går videre.

*Vær oppmerksom på at ovnsåpningen skal vende mot fronten av boosterens.

Trinn 9

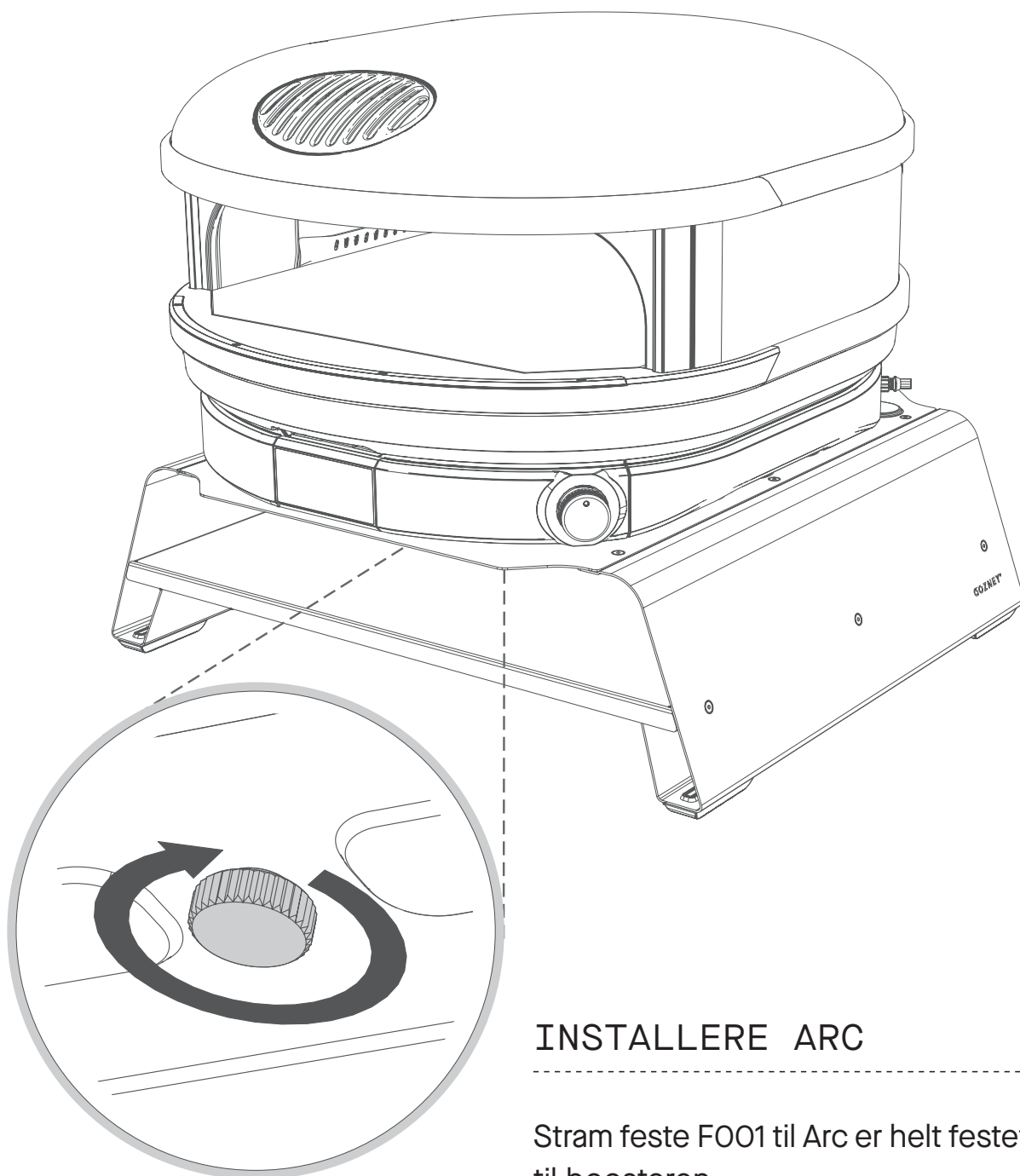

INSTALLERE ARC

Stram feste F001 til Arc er helt festet til boosterens.

Pass på at du ikke strammer for mye da det kan skade boosterens.

Bruk aldri Arc-ovnen uten at den er koblet riktig til boosterens med F001.

חלק זה מפרט מידע חיוני לבטיחות הקשור לשימוש בבוסטר ובתנור Arc.



אזהרות ואמצעי זהירות

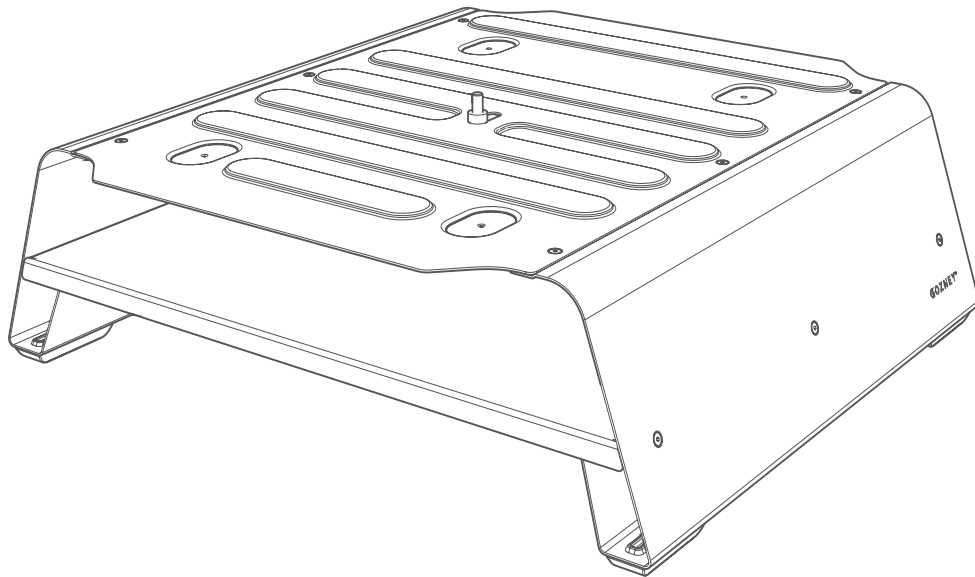

הנחת פריטים חמים מהתנור ישירות על המדף עלולה לגרום לנזק בכיסוי; הקפידו להשתמש באמצעי הגנה מתאים כדי למנוע נזק.

יש להקפיד לקרוא בעיון, להבין ולקיים את אמצעי הזהירות והאזהרות במדריך למשתמש של Arc המצורף לתנור.

לעולם אין לנסות להזיז את התנור כאשר הוא עדיין חם. יש להמתין עד שיתקרר.

בעת הזזת התנור על הבוסטר יש להרים תמיד באמצעות נקודות ההרמה של התנור, לא הבוסטר או המדף.

יש להסיר כל עצם שאינו מקובע הנמצא על הבוסטר והמדפים שלו לפני הזזתו.

צמיעי דהיהרה

הצהורה

חלק זה מפרט את תהליך בניית הבוסטר והתקנתו.



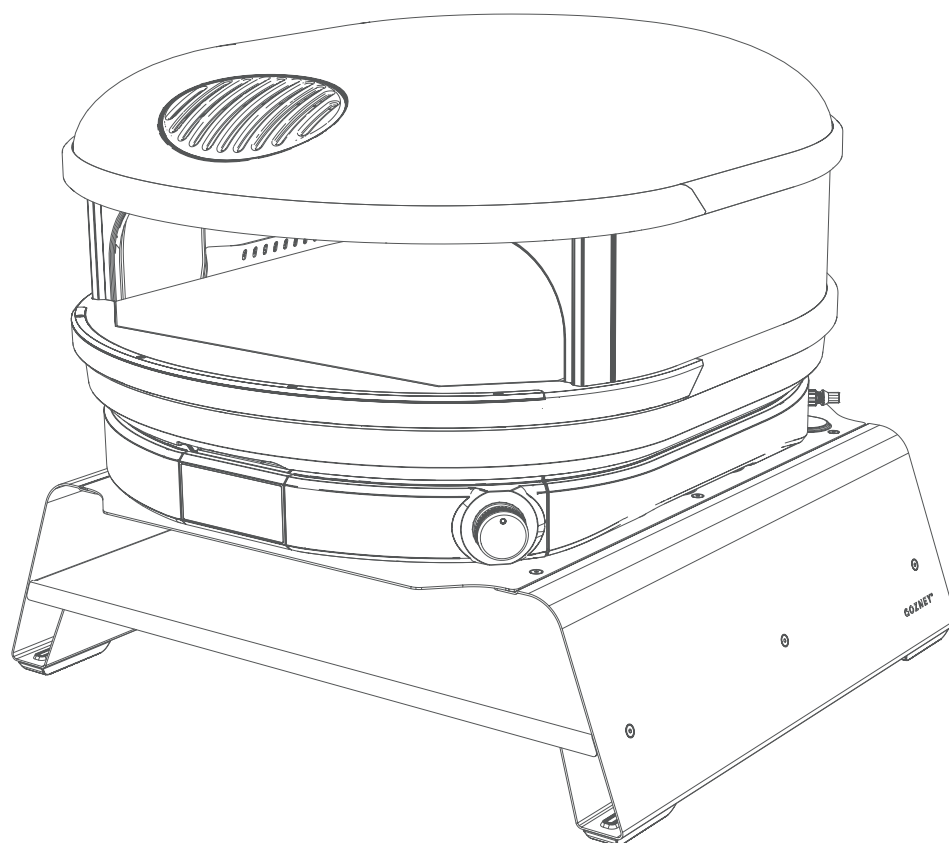

אין להשתמש לעולם בחיבור הגז ובהתקן הניתוק המהיר או בצנרת שלו לצורך הגבלת התנועה של המכשיר.

יש לנתק תמיד את התנור מהגז לפני הזזתו.

יש להקפיד להשתמש בחיבור גז מקורי של Gozney או בחיבור התואם את התקן עבור מכשירי גז ניתנים להזזה (CSA 6.16 / ANSI Z21.69) ובהתקן ניתוק מהיר התואם את התקנים הרלוונטיים (ANSI Z21.41 / CSA 6.9).

מדריך הרכבה

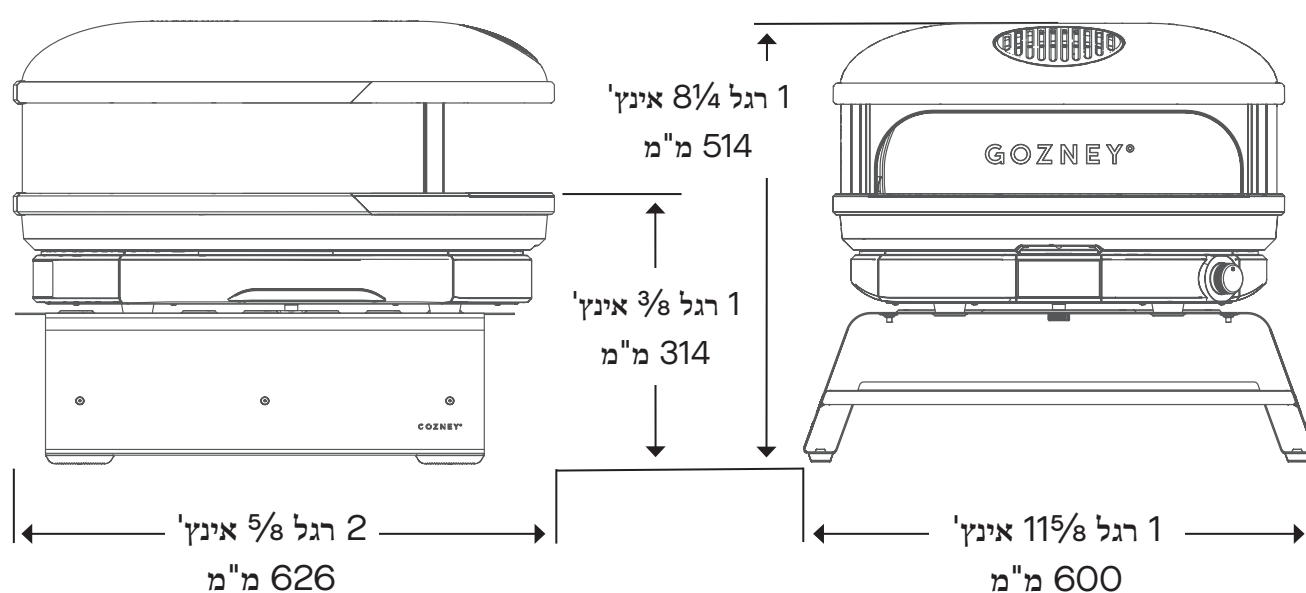

אזור ההרכבה

יש לבנות את הבוסטר באזור שבו אתם מתכוונים למקם את Arc.

יש לוודא שהרצפה יציבה, מאוזנת ומסוגלת לשאת את משקלו של התנור.

אין להניח חלקים כלשהם על המשטח השורט והימנעו מגרימת נזק לצביעה של חלקי המתכת.

הרכבה ואתקנה

שלב 1

קיבועים

אנו ממליצים לא להדק את כל האומים והברגים עד שהבוסטר הורכב.

הדבר יקל על יישור של קיבועים עתידיים. יש לבצע את ההידוק המלא בשלב 6.



F002
3x

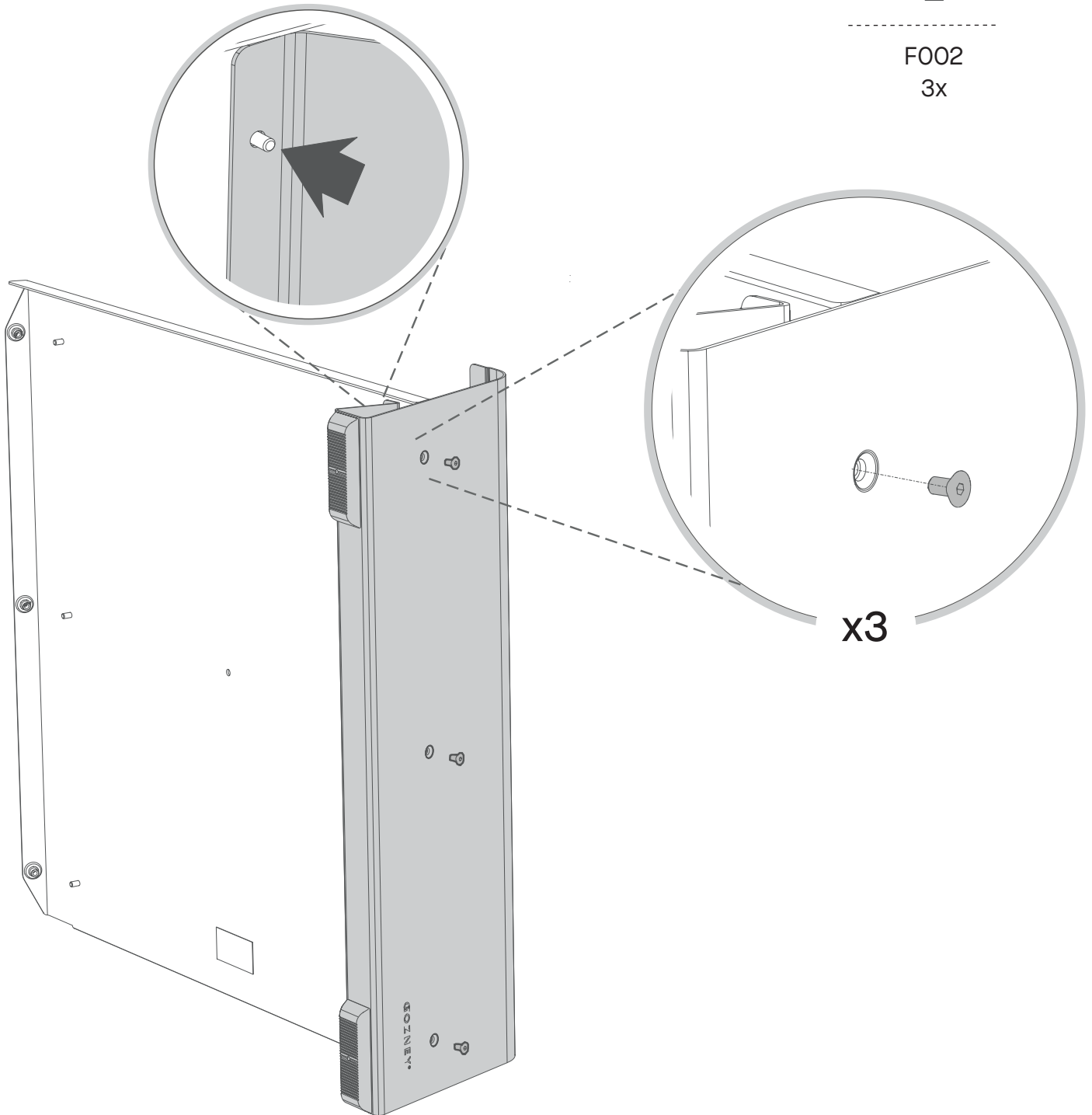

מה באריזה

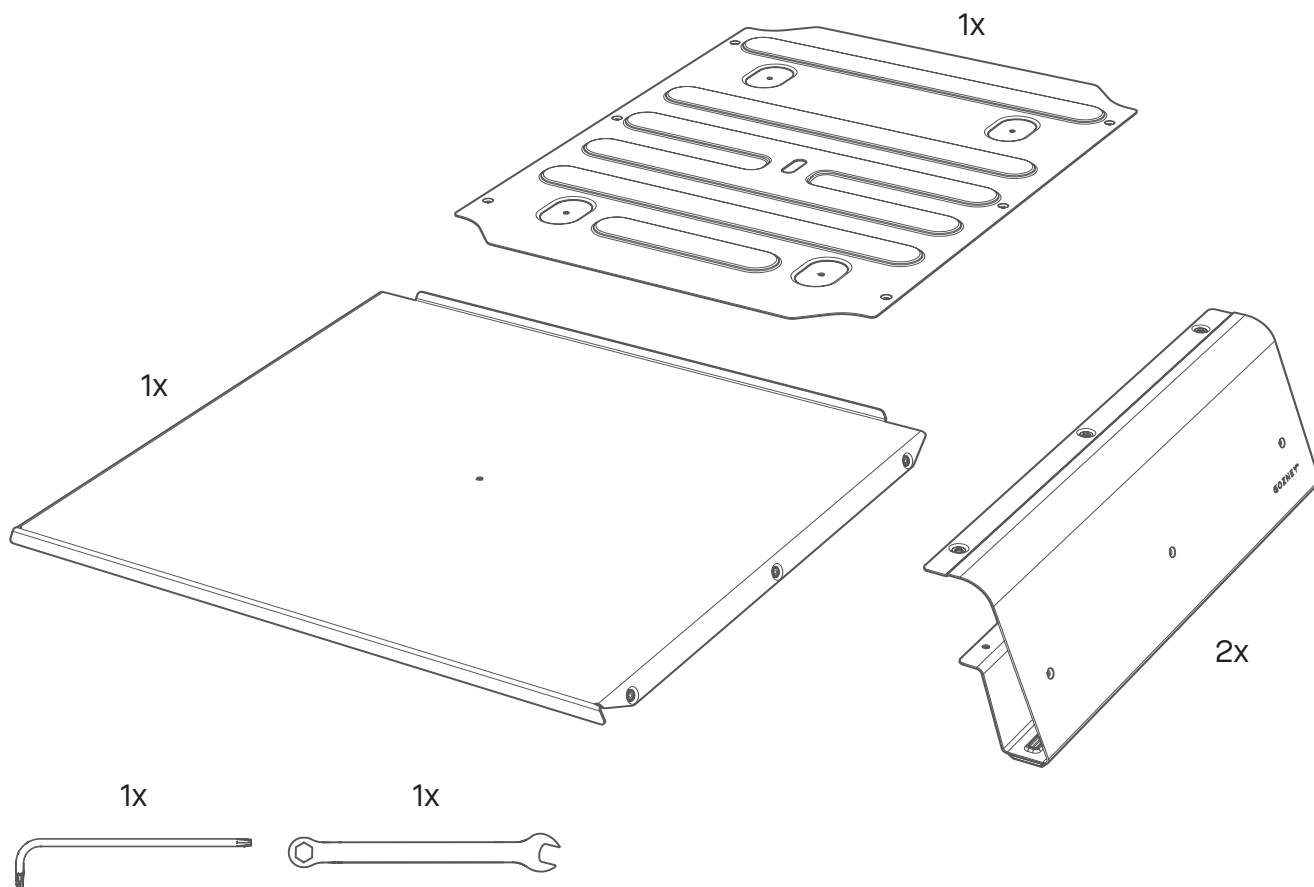

קנה מידה 1:1

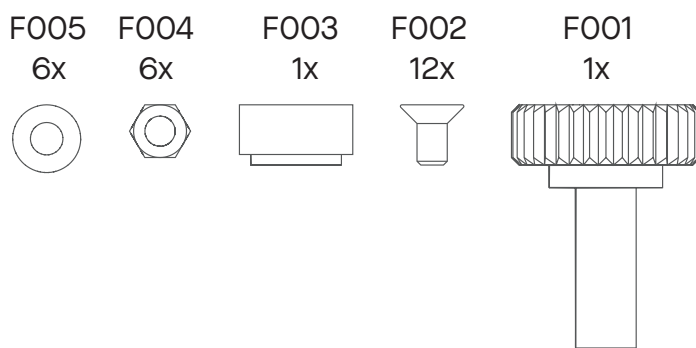



שלב 3

F002
3x

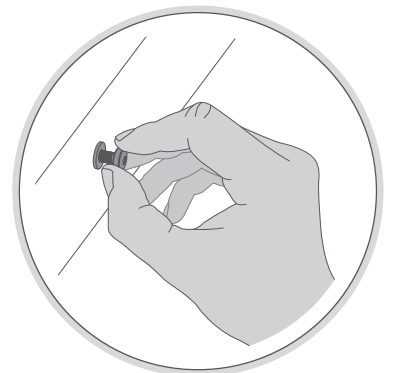
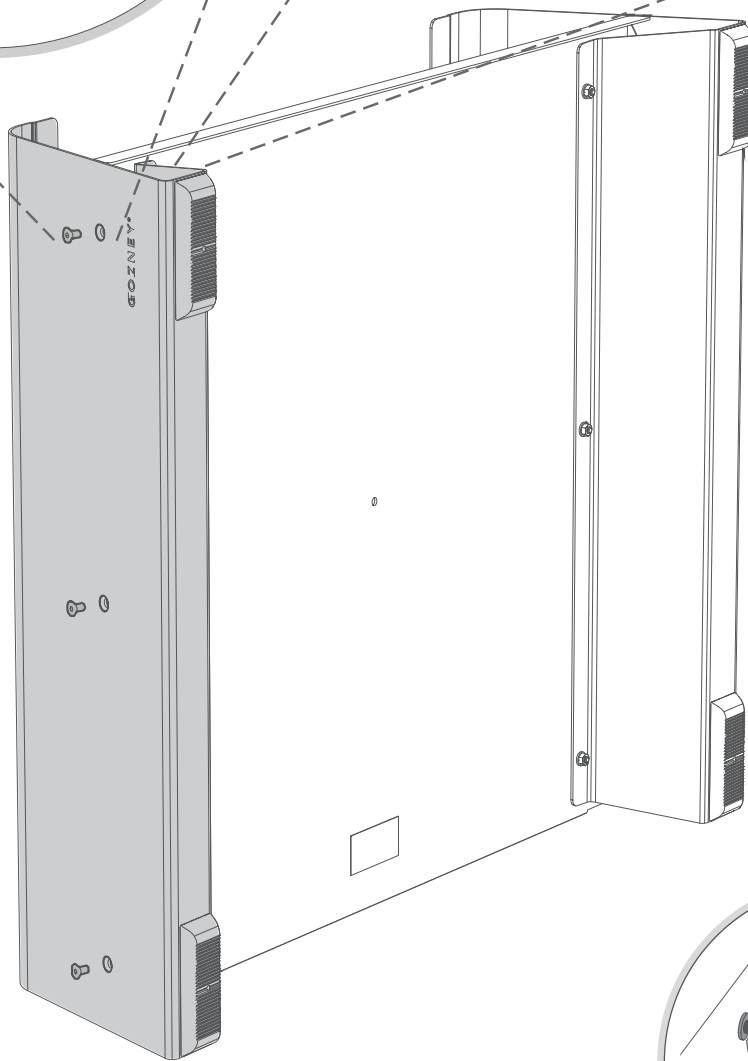
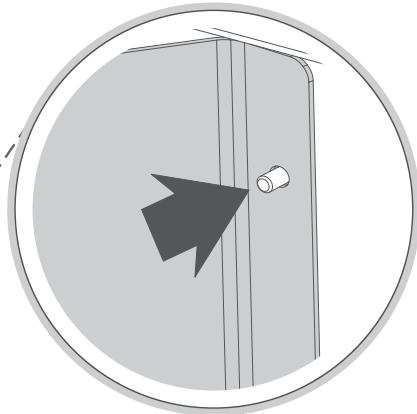
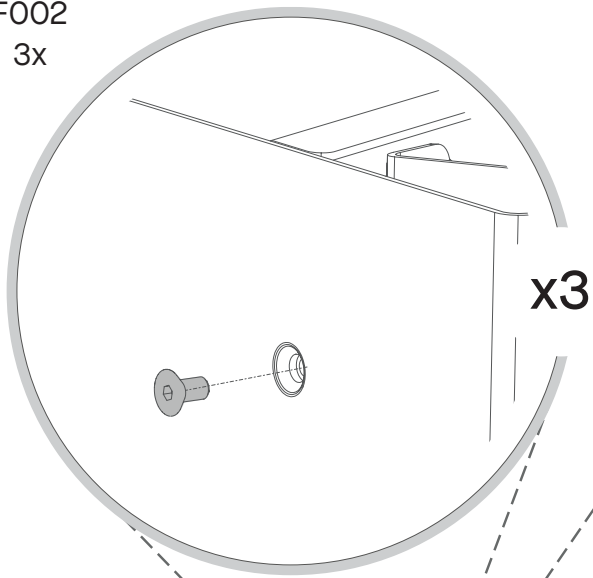



F005
3x

F004
3x

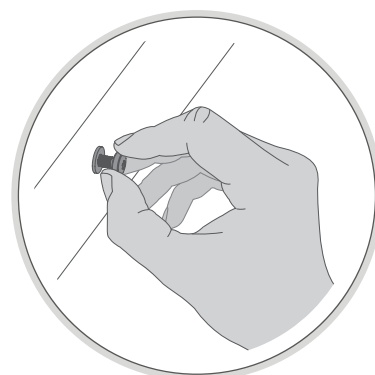
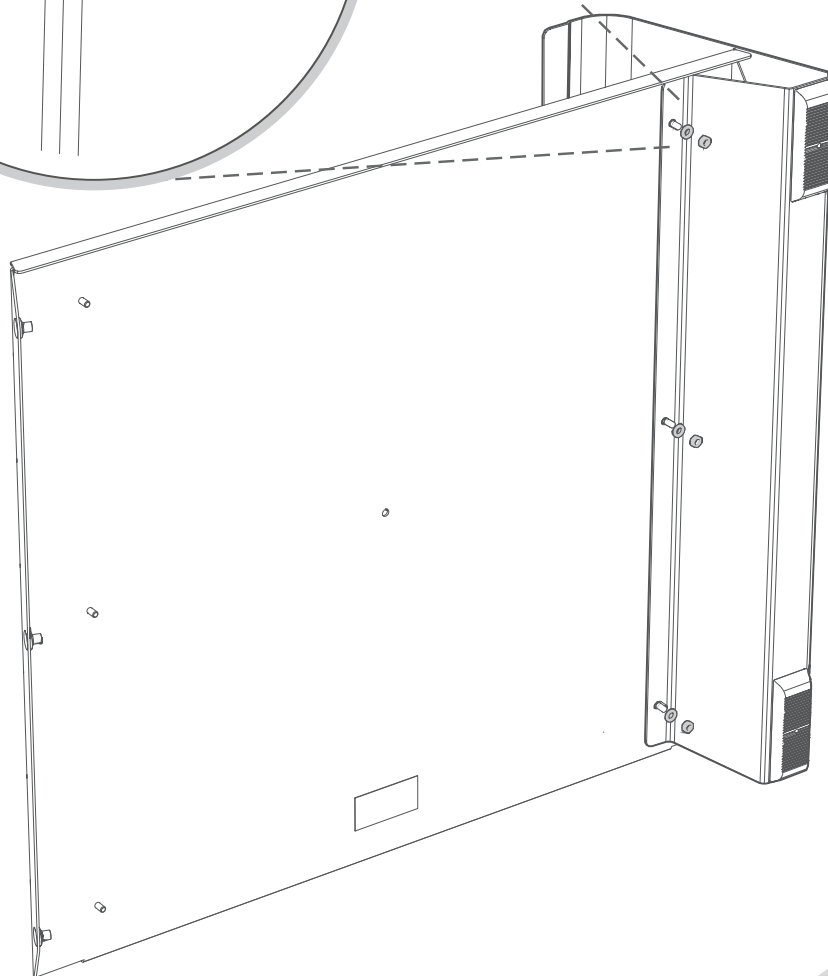
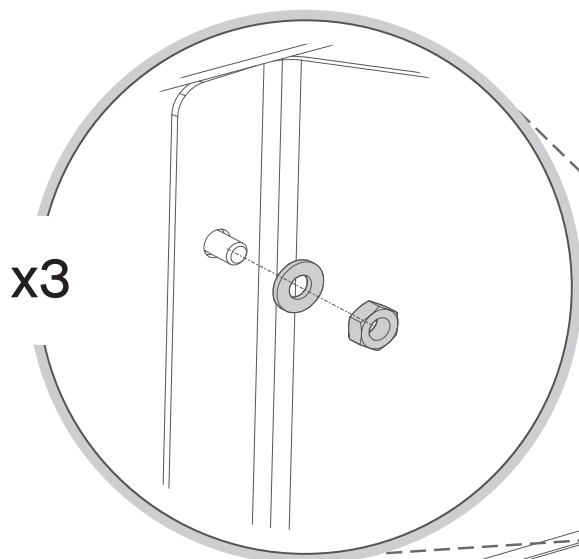



F002
6x

x6

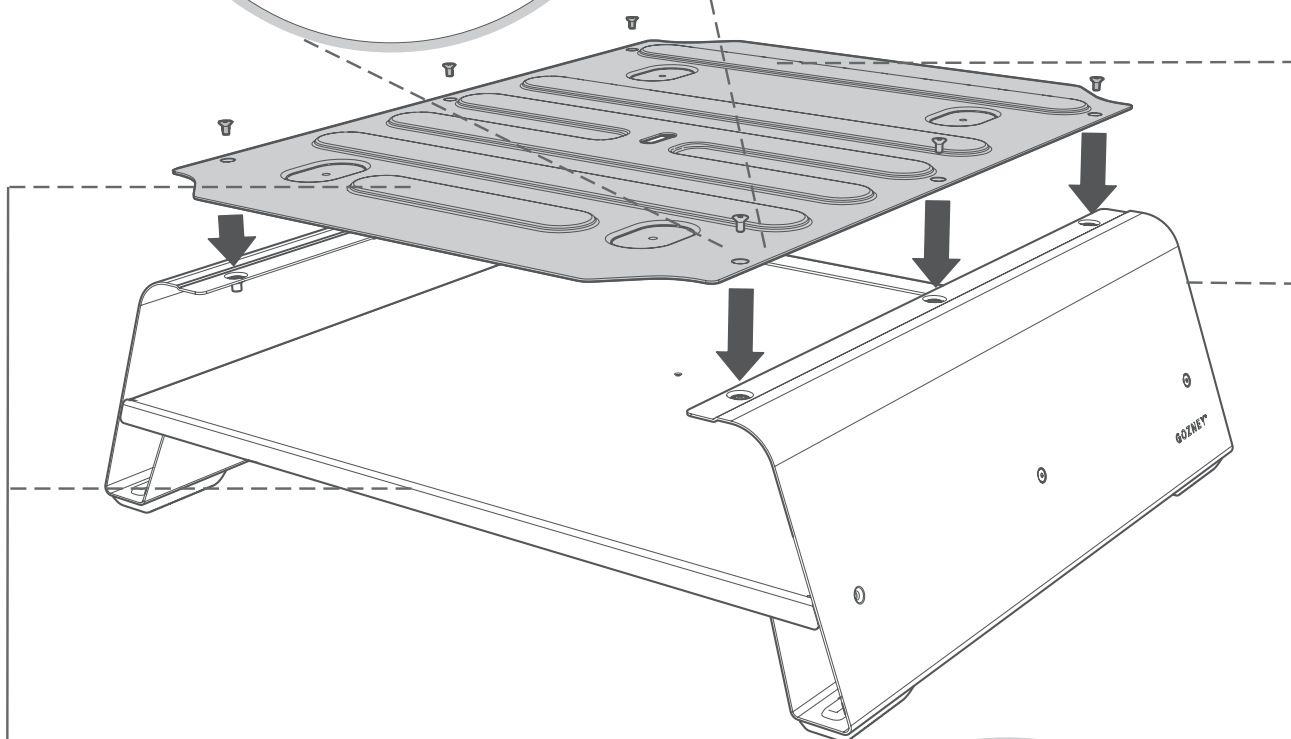
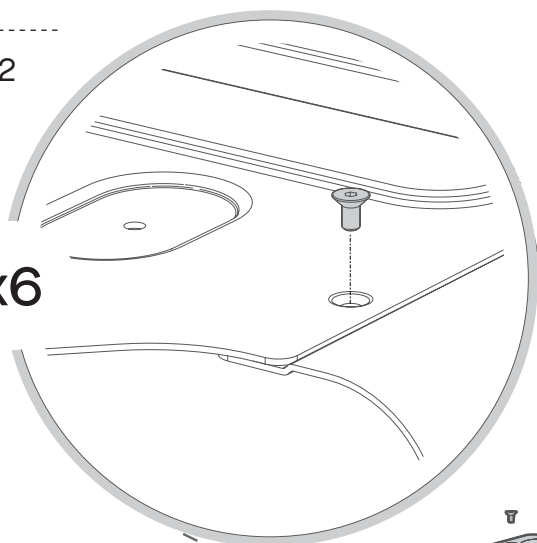

שימו לב ליישור מקדימה



שימו לב ליישור מאחורה



F005
3x

F004
3x

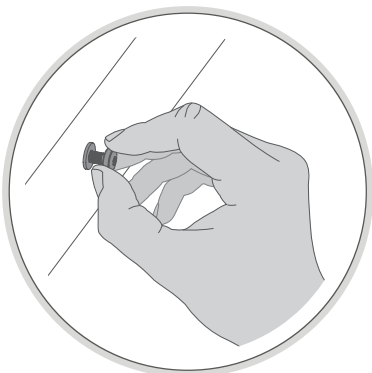
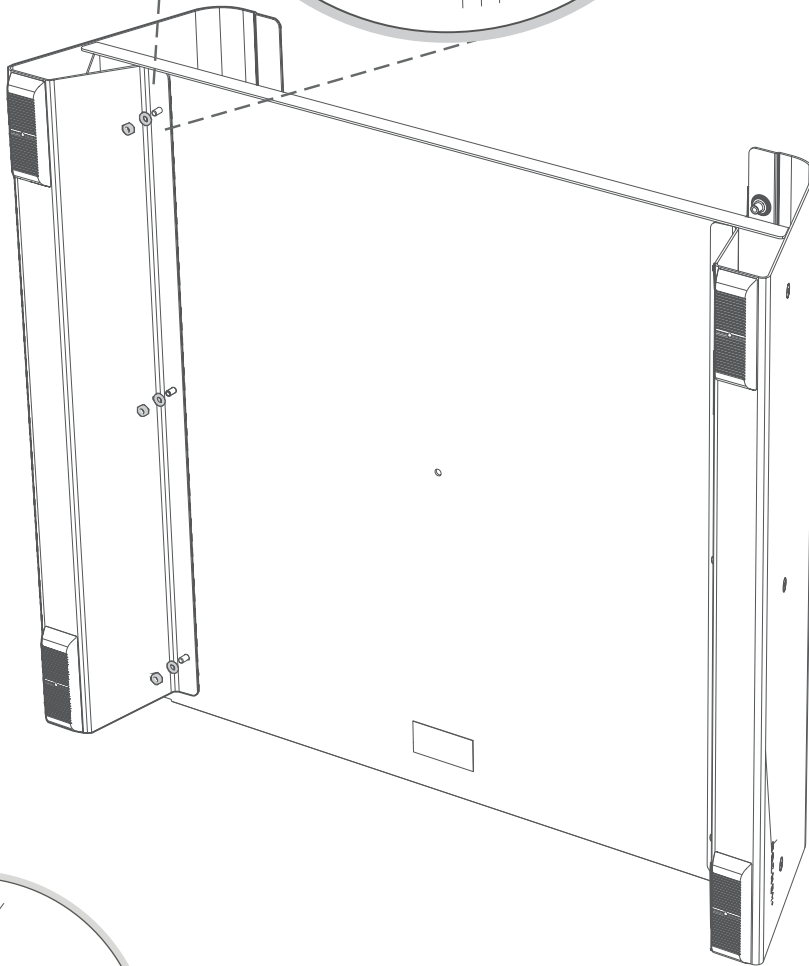
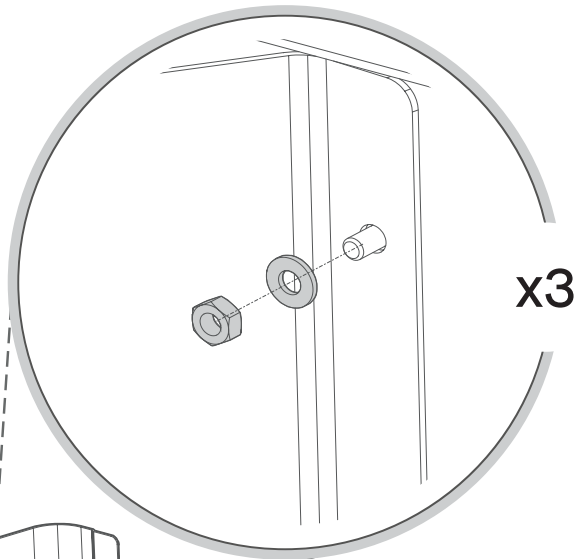

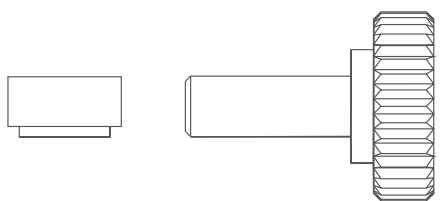

F003
1x

F001
1x

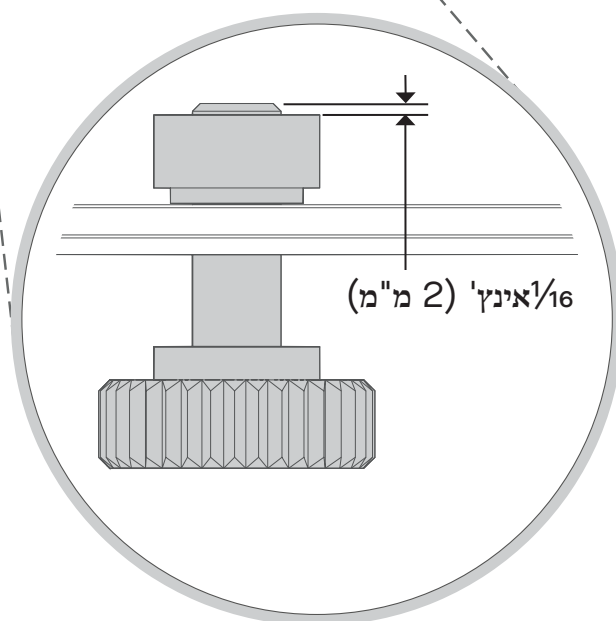
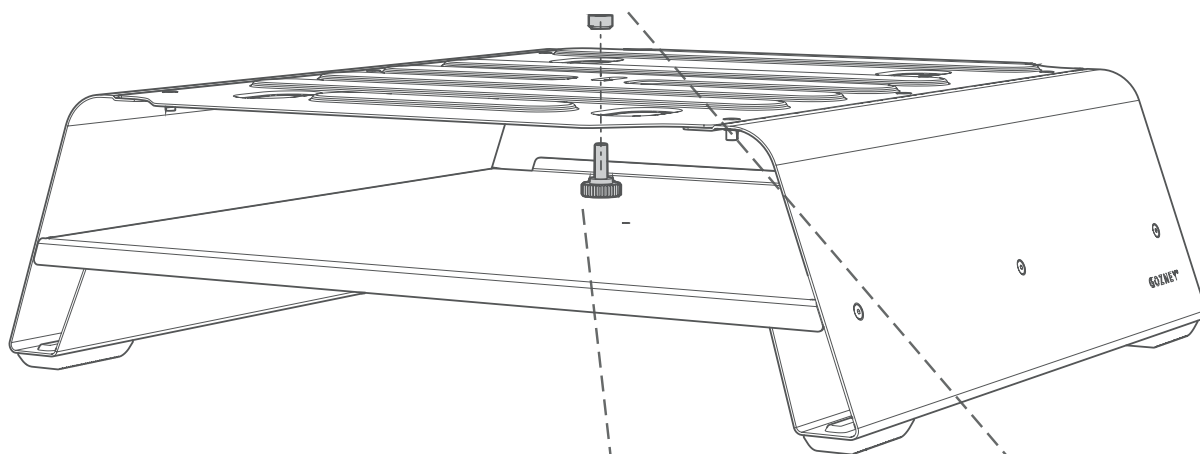

התקנת AR

לפני התקנת Arc, יש להרכיב את החיבורים F001 ו-F003 על החלק העליון של ה-Booster.

אין להדק עד הסוף את שני הקיבועים האלה, על חשיפת החוט לא לחרוג מ-1/16 אינץ' (2 מ"מ)

שלב 6

x12

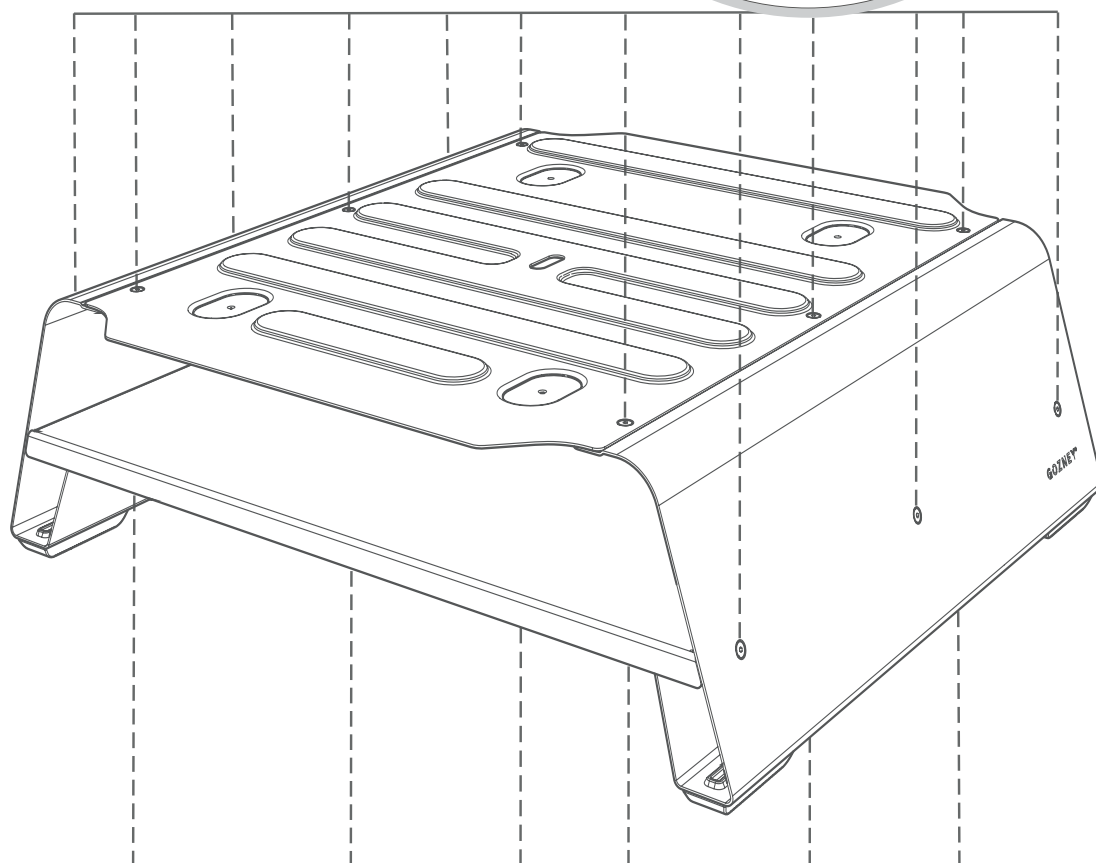
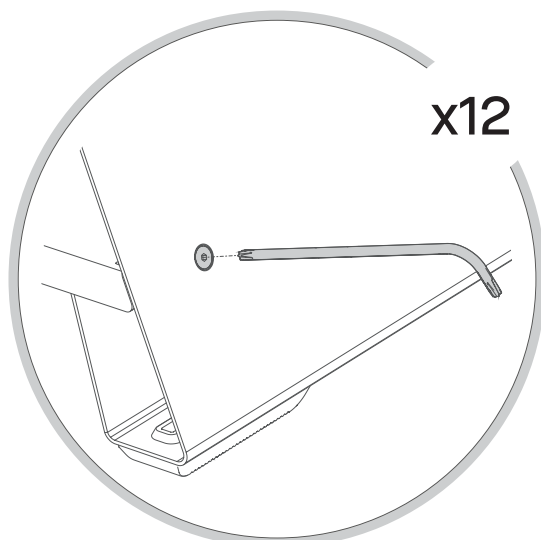

קיבועים

x6

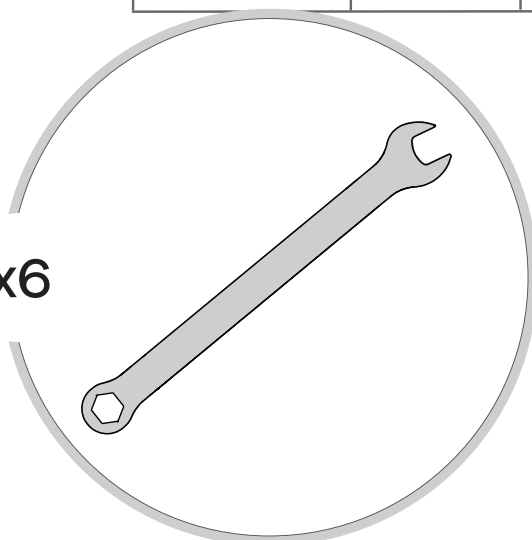

יש להדק את כל הקיבועים על ה-Booster
והיזהרו לא להדק אותם יתר על המידה.

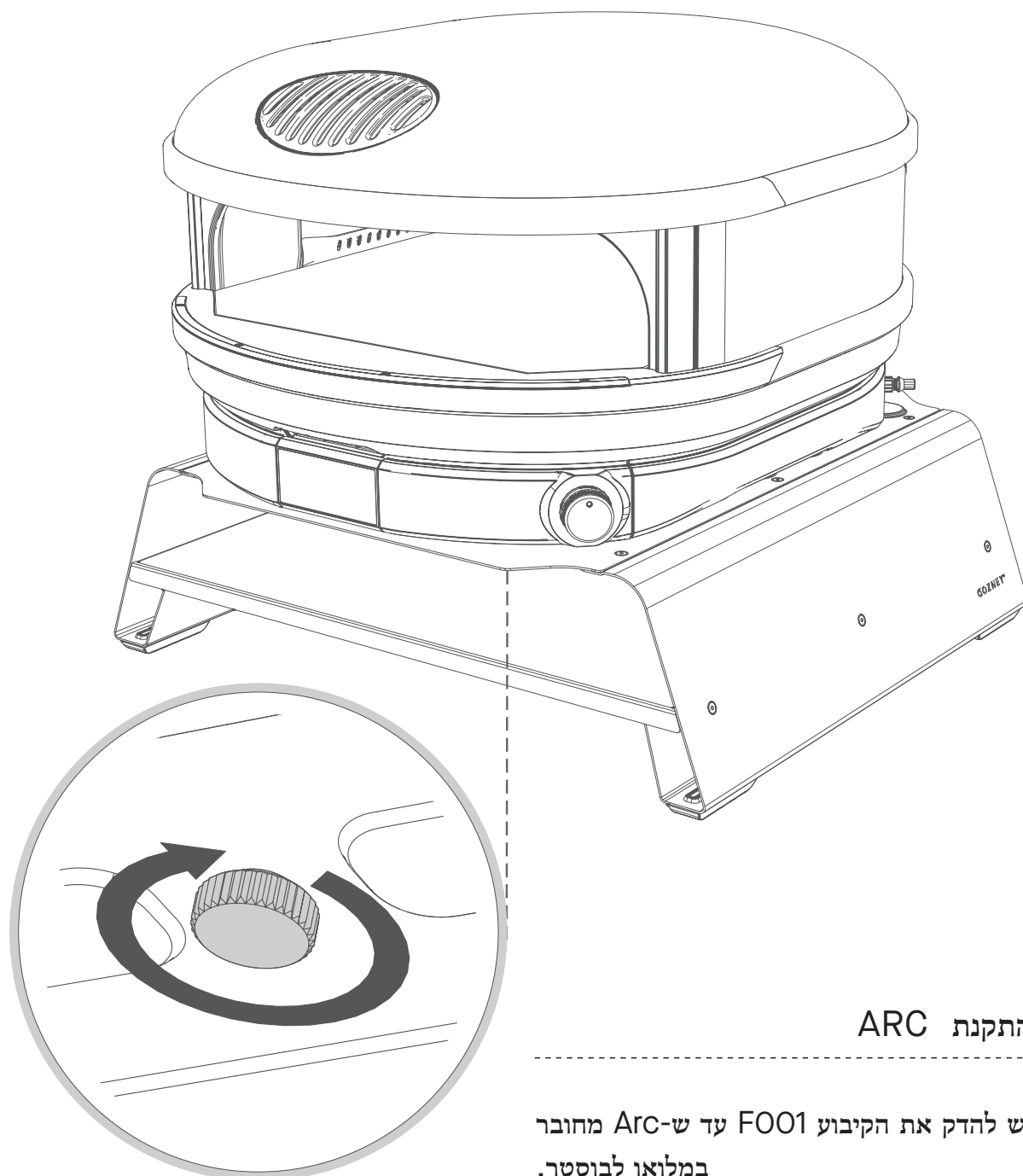

התקנת ARC

יש להדק את הקיבוע F001 עד ש-Arc מחובר במלואו לבוסטר.

יש להיזהר מהידוק יתר, משום שהדבר עלול לגרום נזק ל-Booster.

לעולם אין להשתמש ב-Arc מבלי שהוא יהיה מחובר לבוסטר על ידי F001.

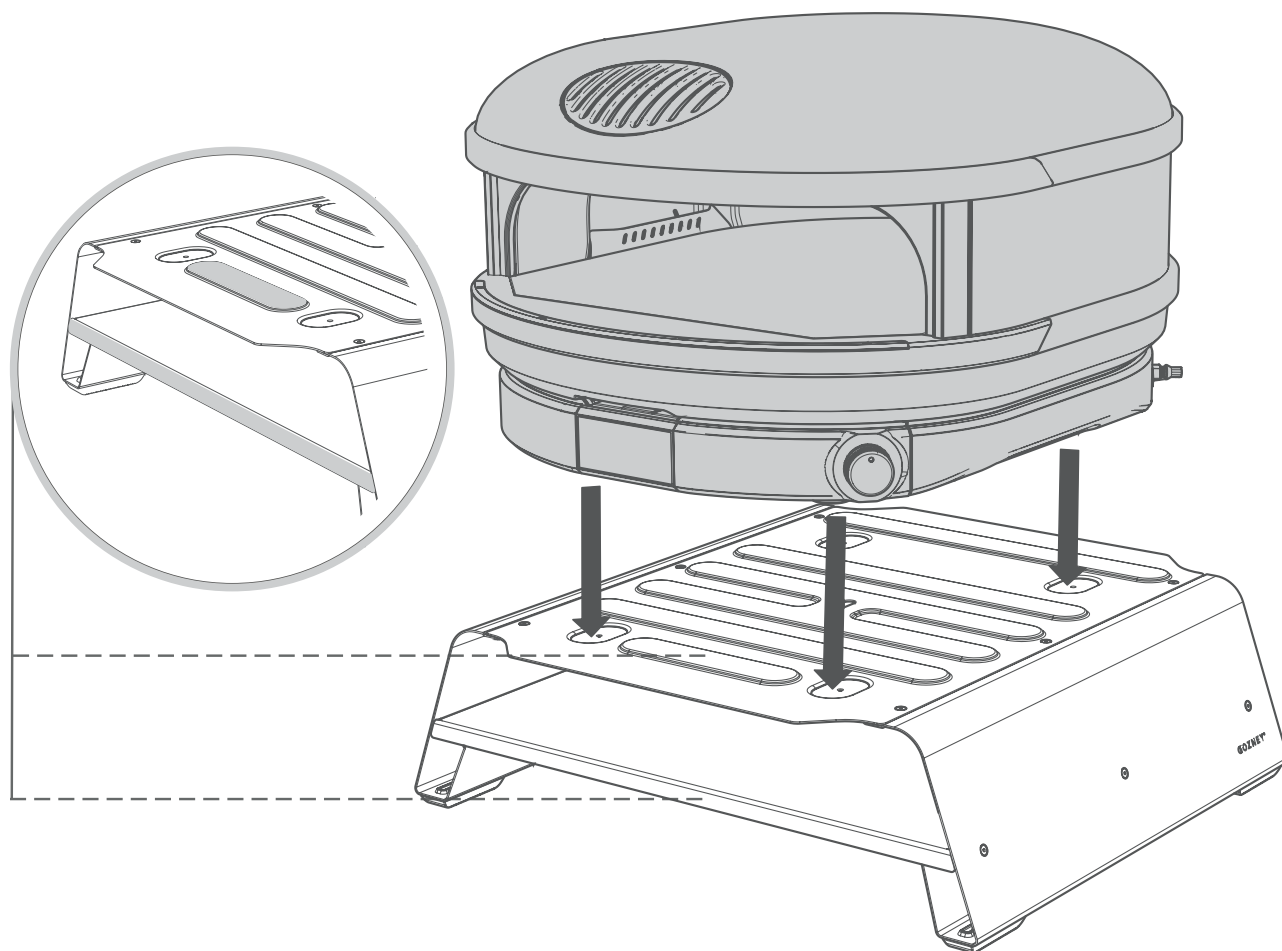

התקנת ARC

יש לוודא שחיבורים F001 ו-F003 מורכבים על ה-Booster לפני התקנת התנור.

יש להסיר את כל העצמים שאינם מקובעים מהתנור לפני ההזזה.

על שני אנשים להרים את ARC מנקודות ההרמה (עיינו במדריך ARC).

לעולם אין להרים את ARC בעצמכם.

אין להשתמש בפתח התנור כנקודת הרמה.

יש ליישר את הרגליות של ARC עם השקעים המודגשים. לפני שתמשיכו, ודאו שהרגליות מיושרות לחלוטין.

*שימו לב שפתח התנור צריך לפנות לצידו הקדמי של הבוסטר.

GOZNEY°